



BALL VALVES

BALL VALVE

3 Way. Bronze PN 10/16

CHARACTERISTICS

Design:

- ◆ Ball valve body. Full bore UNE EN 13547
- ◆ Flange spacing EN 558-1 Series 2 (DIN 3202 F2).
- ◆ Flanges according to EN 1092.
- ◆ Prepared for mounting ISO TOP 5211 actuator.

OPTIONAL CHARACTERISTICS

Integrated Logistics Support (ILS):

- ◆ Technical Documentation (accessible by QR).
- ◆ Spare parts procurement (LCRS).
- ◆ Logistics engineering (obsolescence/costs).

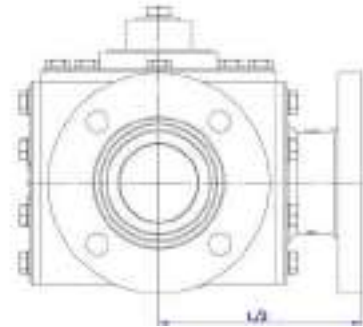
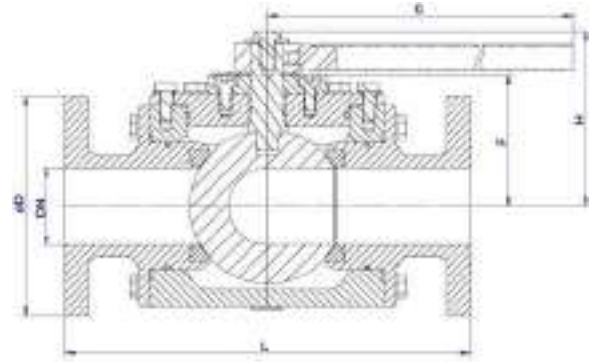

WORKING CONDITIONS

Size	DN	25-100	
Nominal pressure	PN	16	10
Maximum working pressure, kg/cm ²	Up to 100°C	16	10

MATERIALS

- ◆ Hydraulic tightness and sealing test according to EN 12266-1. 100% Valves tested.

DRAWING	BODY	BALL	PACKING	SEAT	STEM	SCREWS	LEVER
TV-706	Bronze (Rg10) (DIN 1705)	Stainless S. A316 (EN10088/DIN17440)	PTFE+GRF	PTFE	Stainless S. A316	Stainless S. A4	Stainless S.
TV-708	Bronze (Rg10) (DIN 1705)	BrNiAl	PTFE+GRF	PTFE	CuAl10Ni	Stainless S. A4	Stainless S.

DIMENSIONS

DN	ØD	L	F	H	G	Top Flange	Torque (Nm)	Weight [kg]	Code SAVAL
25*	115	230	-	-	-	F05	22	-	SDBFxxxTVYY16025
32*	140	260	-	-	-	F05	36	-	SDBFxxxTVYY16032
40	150	260	90	165,5	353	F07	50	30,5	SDBFxxxTVYY16040
50	165	300	105	182,5	353	F07	70	43	SDBFxxxTVYY16050
65	185	340	110	136,5	460	F07	85	62,5	SDBFxxxTVYY16065
80	200	380	121	147,5	750	F10	130	85	SDBFxxxTVYY16080
100	220	430	144	171	750	F10	165	127,5	SDBFxxxTVYY16100

*Upon request
xxx = drawing number
4 way valve option available.

YY = LM Ball in L and motorised
TM Ball in T and motorised

BALL VALVE

2 Way. Flanged. Bronze. Drill ANSI B16.10 150Lbs

CHARACTERISTICS

Design:

- ◆ Two-piece body. Full bore UNE EN 13547.
- ◆ Flange spacing EN 558-1 Series 3 (ANSI B16.10 150Lbs).
- ◆ Flanges according to ANSI B16.5.
- ◆ Prepared for ISO TOP 5211 actuator.

OPTIONAL CHARACTERISTICS

Integrated Logistics Support (ILS):

- ◆ Technical Documentation (accessible by QR).
- ◆ Spare parts procurement (LCRS).
- ◆ Logistics engineering (obsolescence/costs).

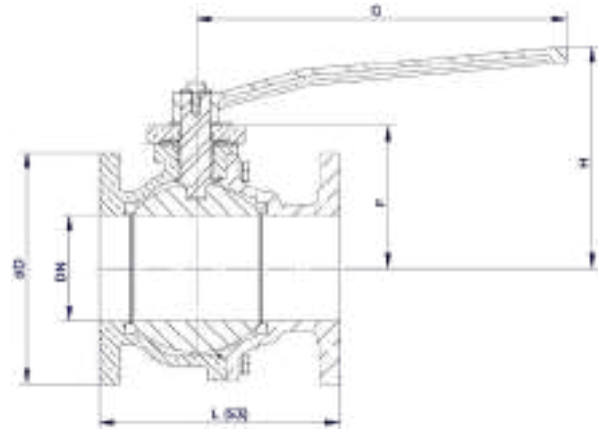

WORKING CONDITIONS

Size	DN	15-100
Nominal pressure	PN	16 10
Maximum working pressure, kg/cm ²	Up to 100°C	16 10

MATERIALS

- ◆ Hydraulic tightness and sealing test according to EN 12266-1. 100% Valves tested.

DRAWING	BODY	BALL	SEAT	STEM	SCREWS	LEVER
BF-708-S3	Bronze (Rg10) (DIN 1705)	BrNiAl	PTFE	CuAl10Ni	Stainless S. A4	Stainless S.

DIMENSIONS

DN	ØD	L(S3)	F	H	G	Top Flange	Torque (Nm)	Weight [kg]	Code SAVAL
15	95	108	48	100,5	181,5	F05	8	5	SDBF7082AS315015
20	105	117	58	111	181,5	F05	10	7	SDBF7082AS315020
25	115	127	62	115	181,5	F05	15	8	SDBF7082AS315025
32	140	140	68	120	181,5	F05	20	10	SDBF7082AS315032
40	150	165	81	142	216	F07	30	10	SDBF7082AS315040
50	165	178	89	150	216	F07	45	13,5	SDBF7082AS315050
65	185	190	101	162	216	F07	55	18	SDBF7082AS315065
80	200	203	121	197	353	F10	85	25,5	SDBF7082AS315080
100	220	229	134	210	353	F10	110	33,5	SDBF7082AS315100

BALL VALVE

2 Way. Flanged. Bronze PN 10/16

CHARACTERISTICS

Design:

- ◆ Two-piece body. Full bore UNE EN 13547.
- ◆ Flange spacing EN 558-1 Series 14 (DIN 3202 F4).
- ◆ Flanges according to EN 1092.
- ◆ Prepared for ISO TOP 5211 actuator.

OPTIONAL CHARACTERISTICS

Integrated Logistics Support (ILS):

- ◆ Technical Documentation (accessible by QR).
- ◆ Spare parts procurement (LCRS).
- ◆ Logistics engineering (obsolescence/costs).

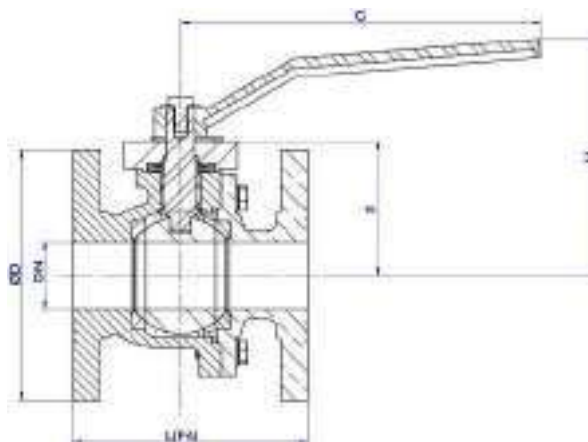

WORKING CONDITIONS

Size	DN	15-100
Nominal pressure	PN	16 10
Maximum working pressure, kg/cm ²	Up to 100°C	16 10

MATERIALS

- ◆ Hydraulic tightness and sealing test according to EN 12266-1. 100% Valves tested.

DRAWING	BODY	BALL	SEAT	STEM	SCREWS	LEVER
BF-706	Bronze (Rg10) (DIN 1705)	Stainless S. A316 (EN10088/DIN17440)	PTFE	Stainless S. (AISI316)	Stainless S. A4	Stainless S.
BF-708	Bronze (Rg10) (DIN 1705)	BrNiAl	PTFE	CuAl10Ni	Stainless S. A4	Stainless S.

DIMENSIONS

DN	ØD	L(F4)	F	H	G	Top Flange	Torque	Weight	Code
								[kg]	SAVAL
15	95	115	48	100,5	181,5	F05	8	4	SDBFxxx2AF415015
20	105	120	58	111	181,5	F05	10	5	SDBFxxx2AF415020
25	115	125	62	115	181,5	F05	15	6	SDBFxxx2AF415025
32	140	130	68	120	181,5	F05	20	7,5	SDBFxxx2AF415032
40	150	140	81	142	216	F07	30	10	SDBFxxx2AF415040
50	165	150	89	150	216	F07	45	13,5	SDBFxxx2AF415050
65	185	170	101	162	216	F07	55	17	SDBFxxx2AF415065
80	200	180	121	197	353	F10	85	25	SDBFxxx2AF415080
100	220	190	134	210	353	F10	110	32	SDBFxxx2AF415100

xxx = drawing number

BALL VALVE

2 Way. Flanged. Mild Steel PN 10/16

CHARACTERISTICS

Design:

- ◆ Two-piece body. Full bore UNE EN 1983:2014
- ◆ Flange spacing EN 558-1 Serie 14 (DIN 3202 F4)
- ◆ Flanges according to EN 1092.
- ◆ Prepared for ISO TOP 5211 actuator.

OPTIONAL CHARACTERISTICS

Integrated Logistics Support (ILS):

- ◆ Technical Documentation (accessible by QR).
- ◆ Spare parts procurement (LCRS).
- ◆ Logistics engineering (obsolescence/costs).

WORKING CONDITIONS

Size	DN	15-100
Nominal pressure	PN	10 16
Maximum working pressure, kg/cm ²	Up to 100°C	9,4 15

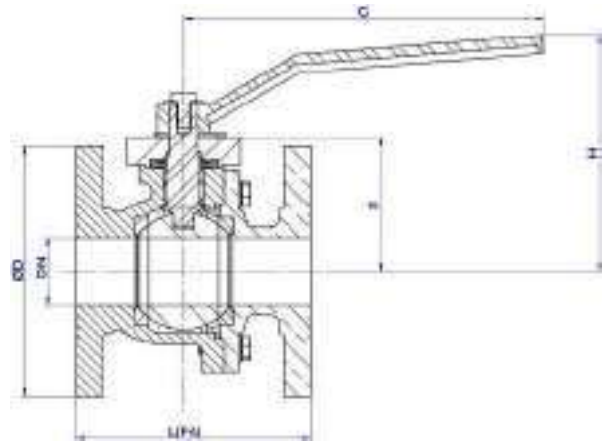

MATERIALS

- ◆ Hydraulic tightness and sealing test according to EN 12266-1. 100% Valves tested.

DRAWING	BODY	BALL	SEATS	BODY ENDS	BOLTING	LEVER
BF-206	Mild Steel (GS-C-25) (EN10213/DIN17245)	Stainless Steel A316 (EN10088/DIN17440)	PTFE	Stainless Steel (AISI 316)	Stainless Steel A4	Stainless Steel

DIMENSIONS

DN	ØD	L	F	H	G	ISO Top Flange	Torque	Weight BF-206 [kg]	Code
mm	mm	mm	mm	mm	mm				SAVAL
15	95	115	48	100,5	181,5	F05	8	3,5	SDBF2062AF416015
20	105	120	58	111	181,5	F05	10	4,5	SDBF2062AF416020
25	115	125	62	115	181,5	F05	15	5,5	SDBF2062AF416025
32	140	130	68	120	181,5	F05	20	7	SDBF2062AF416032
40	150	140	81	142	216	F07	30	9,5	SDBF2062AF416040
50	165	150	89	150	216	F07	45	12,5	SDBF2062AF416050
65	185	170	101	162	216	F07	55	16,5	SDBF2062AF416065
80	200	180	121	197	353	F10	85	24	SDBF2062AF416080
100	220	190	134	210	353	F10	100	30,5	SDBF2062AF416100

BALL VALVE

2 Way. Flanged. Stainless Steel PN 10/16

CHARACTERISTICS

Design:

- ◆ Two-piece body. Full bore UNE EN 1983:2014
- ◆ Flange spacing EN 558-1 Series 14 (DIN 3202 F4).
- ◆ Flanges according to EN 1092.
- ◆ Prepared for ISO TOP 5211 actuator.

OPTIONAL CHARACTERISTICS

Integrated Logistics Support (ILS):

- ◆ Technical Documentation (accessible by QR).
- ◆ Spare parts procurement (LCRS).
- ◆ Logistics engineering (obsolescence/costs).

WORKING CONDITIONS

Size	DN	15-100	
Nominal pressure	PN	10	16
Maximum working pressure, kg/cm ²	Up to 100°C	9,5	15,2

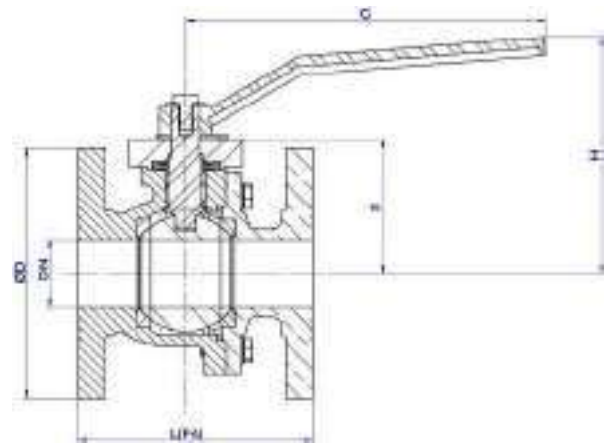

MATERIALS

- ◆ Hydraulic tightness and sealing test according to EN 12266-1. 100% Valves tested.

DRAWING	BODY	BALL	SEATS	BODY ENDS	BOLTING	LEVER
BF-606	Stainless Steel (AISI316)	Stainless Steel A316 (EN10088/DIN17440)	PTFE	Stainless Steel (AISI 316)	Stainless Steel A4	Stainless Steel

DIMENSIONS

DN	ØD	L	F	H	G	ISO Top Flange	Torque	Weight BF-606 [kg]	Code
mm	mm	mm	mm	mm	mm				SAVAL
15	95	115	48	100,5	181,5	F05	8	3,5	SDBF6062AF416015
20	105	120	58	111	181,5	F05	10	4,5	SDBF6062AF416020
25	115	125	62	115	181,5	F05	15	5,5	SDBF6062AF416025
32	140	130	68	120	181,5	F05	20	7	SDBF6062AF416032
40	150	140	81	142	216	F07	30	9,5	SDBF6062AF416040
50	165	150	89	150	216	F07	45	12,5	SDBF6062AF416050
65	185	170	101	162	216	F07	55	16,5	SDBF6062AF416065
80	200	180	121	197	353	F10	85	24	SDBF6062AF416080
100	220	190	134	210	353	F10	100	30,5	SDBF6062AF416100

BALL VALVE

2 - Way - Socket Weld. Bronze. PN 25

CHARACTERISTICS

Design:

- ◆ Three-piece body. Full bore UNE EN 13547.
- ◆ Welded connection UNE-EN 13547:2014

OPTIONAL CHARACTERISTICS

Integrated Logistics Support (ILS):

- ◆ Technical Documentation (accessible by QR).
- ◆ Spare parts procurement (LCRS).
- ◆ Logistics engineering (obsolescence/costs).

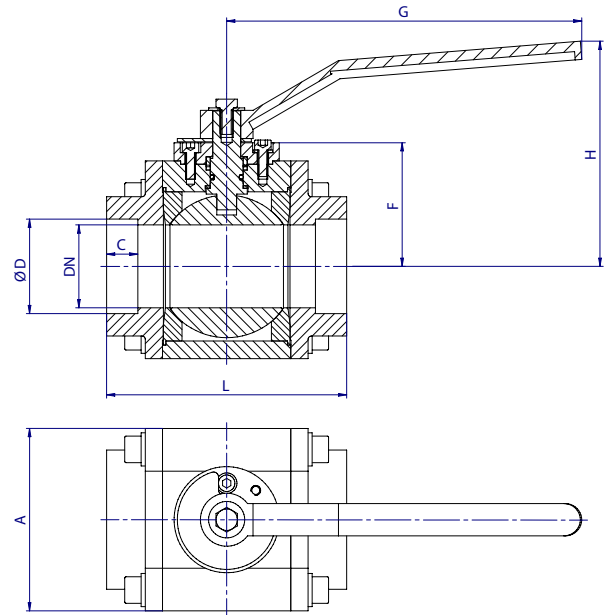

◆ Hydraulic tightness and sealing test according to EN 12266-1. 100% Valves tested.

WORKING CONDITIONS

Size	DN	8-50
Nominal pressure	PN	25
Maximum working pressure, kg/cm ²	Up to 100°	25

MATERIALS

DRAWING	BODY	BALL	STEM	SEAT	BODY ENDS	BOLTING	LEVER
BW-806	Bar CuAl10Ni	Stainless S. A316 (EN10088/DIN17440)	CuAl10Ni	PTFE	CuAl10Ni	Stainless S. A4	Stainless S.
BW-808	Bar CuAl10Ni	BrNiAl	CuAl10Ni	PTFE	CuAl10Ni	Stainless S. A4	Stainless S.

DIMENSIONS

DN		ØD	A	L	C (min)	H	F	Top Flange	G	Torque	Weight	Code
Inches	mm	mm	mm	mm	mm	mm	mm		mm	(Nm)	[kg]	
1/4	8	12	56	72	10	92	39	F03	181	8	1,7	SDBFxxxN3ASW25008
3/8	10	16	56	72	10	92	39	F03	181	8	1,7	SDBFxxxN3ASW25010
1/2	15	20	56	72	10	92	39	F03	181	8	1,7	SDBFxxxN3ASW2501520
3/4	20	25	56	81	13	92	39	F03	181	10	1,8	SDBFxxxN3ASW25020
1	25	30	68	85	13	98	45	F03	181	15	2,5	SDBFxxxN3ASW25025
1 1/4	32	38	80	96	13	103,5	51	F03	181	20	3,6	SDBFxxxN3ASW25032
1 1/2	40	44,5	100	118	13	129	68	F05	216	30	6,3	SDBFxxxN3ASW25040
2	50	57	110	141	16	136	75	F05	216	45	10	SDBFxxxN3ASW25050

xxx = drawing number

BALL VALVE

2 - Way - Socket Weld. Mild Steel PN 40

CHARACTERISTICS

Design:

- ◆ Three-piece body. Full bore UNE EN 13547.
- ◆ Welded connection UNE-EN 13547:2014

OPTIONAL CHARACTERISTICS

Integrated Logistics Support (ILS):

- ◆ Technical Documentation (accessible by QR).
- ◆ Spare parts procurement (LCRS).
- ◆ Logistics engineering (obsolescence/costs).

WORKING CONDITIONS

Size	DN	8-50
Nominal pressure	PN	40
Maximum working pressure, kg/cm ²	Up to 100°C	40

MATERIALS

DRAWING	BODY	BALL	STEM	SEATS	BODY ENDS	BOLTING	LEVER
BW-206	Mild Steel A150/P355	Stainless Steel (AISI 316)	Stainless Steel (AISI 316)	PTFE	Mild Steel A105/P355	Stainless Steel A4	Stainless Steel AISI304

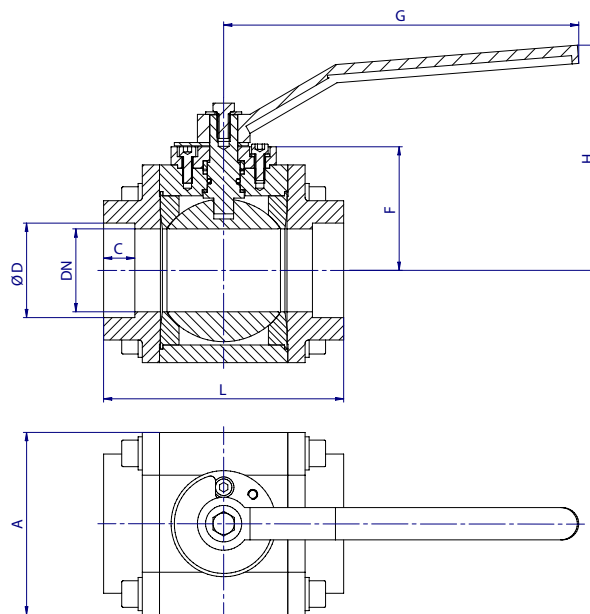

- ◆ Hydraulic tightness and sealing test according to EN 12266-1. 100% Valves tested.

DIMENSIONS

DN		ØD	A	L	C (min)	H	M	Top Flange	G	Torque (Nm)	Weight [kg]	Code
Inches	mm	mm	mm	mm	mm	mm	mm					
1/4	8	14,1	56	72	10	92	39	F03	181	8	1,7	SDBF206N3ASW40008
3/8	10	17,6	56	72	10	92	39	F03	181	8	1,7	SDBF206N3ASW40010
1/2	15	21,8	56	72	10	92	39	F03	181	8	1,7	SDBF206N3ASW4001520
3/4	20	27,1	56	81	13	93	39	F03	181	10	1,8	SDBF206N3ASW40020
1	25	33,8	68	85	13	98	45	F03	181	15	2,5	SDBF206N3ASW40025
1 1/4	32	42,5	80	96	13	103,5	51	F03	181	20	3,6	SDBF206N3ASW40032
1 1/2	40	48,5	100	118	13	129	68	F05	216	30	6,5	SDBF206N3ASW40040
2	50	57	110	146	19	136	75	F05	216	45	9	SDBF206N3ASW40050

BALL VALVE

2 - Way - Socket Weld. Stainless Steel. PN 40

CHARACTERISTICS

Design:

- ◆ Three-piece body. Full bore UNE EN 13547.
- ◆ Welded connection UNE-EN 13547:2014

OPTIONAL CHARACTERISTICS

Integrated Logistics Support (ILS):

- ◆ Technical Documentation (accessible by QR).
- ◆ Spare parts procurement (LCRS).
- ◆ Logistics engineering (obsolescence/costs).

WORKING CONDITIONS

Size	DN	8-50
Nominal pressure	PN	40
Maximum working pressure, kg/cm ²	Up to 100°C	38,1

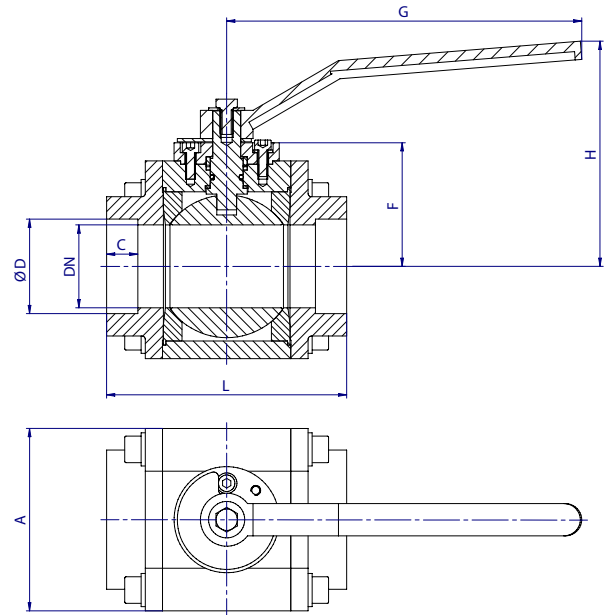

◆ Hydraulic tightness and sealing test according to EN 12266-1. 100% Valves tested.

MATERIALS

DRAWING	BODY	BALL	STEM	SEATS	BODY ENDS	BOLTING	LEVER
BW-606	Stainless Steel (AISI 316)	Stainless Steel (AISI 316)	Stainless Steel (AISI 316)	PTFE	Stainless Steel (AISI 316)	Stainless Steel A4	Stainless Steel AISI304

DIMENSIONS

DN		ØD	A	L	C (min)	H	F	Top Flange	G	Torque	Weight	Code
Inches	mm	mm	mm	mm	mm	mm	mm		mm	(Nm)	[kg]	SAVAL
1/4	8	14,1	56	72	10	92	39	F03	181	8	1,7	SDBF606N3ASW40008
1/2	15	21,7	56	72	10	92	39	F03	181	8	1,7	SDBF606N3ASW4001520
3/4	20	27,1	56	81	13	93	39	F03	181	10	1,8	SDBF606N3ASW40020
1	25	33,8	68	85	13	98	45	F03	181	15	2,5	SDBF606N3ASW40025
1 1/4	32	42,5	80	96	13	103,5	51	F03	181	20	3,6	SDBF606N3ASW40032
1 1/2	40	48,6	100	118	13	129	68	F05	216	30	6,5	SDBF606N3ASW40040
2	50	57	110	146	19	136	75	F05	216	45	9	SDBF606N3ASW40050

BALL VALVE

2 Way. Threaded. Manual. Bronze PN40

CHARACTERISTICS

Design:

- ◆ Three-piece body. Full bore EN 1983.

OPTIONAL CHARACTERISTICS

Integrated Logistics Support (ILS):

- ◆ Technical Documentation (accessible by QR).
- ◆ Spare parts procurement (LCRS).
- ◆ Logistics engineering (obsolescence/costs).

WORKING CONDITIONS

Size	DN	8-50
Nominal pressure	PN	40
Maximum working pressure, kg/cm ²	Up to 100°C	40

MATERIALS

DRAWING	BODY	BALL	STEM	SEATS	BODY ENDS	BOLTING	LEVER
BR-808	CuAl10Ni bar	BrNiAl	CuAl10Ni	PTFE	CuAl10Ni	Stainless Steel A4	Stainless Steel

DIMENSIONS

DN		ØD	A	L	C (min)	H	F	G	Weight	Code
Inches	mm	mm	mm	mm	mm	mm	mm	mm	[kg]	SAVAL
1/4	8	1/4	56	75	12	92	39	181	2	SDBF808N3AER40008
3/8	10	3/8	56	75	12	92	39	181	2	SDBF808N3AER40010
1/2	15	1/2	56	83	15	92	39	181	2	SDBF808N3AER40015
3/4	20	3/4	56	87	17	92	39	181	2	SDBF808N3AER40020
1	25	1	68	95	18	98	45	181	2,5	SDBF808N3AER40025
1 1/4	32	1 1/4	80	110	20	104	51	181	3,5	SDBF808N3AER40032
1 1/2	40	1 1/2	100	128	23	129	68	216	6,5	SDBF808N3AER40040
2	50	2	110	155	25	136	75	216	9	SDBF808N3AER40050

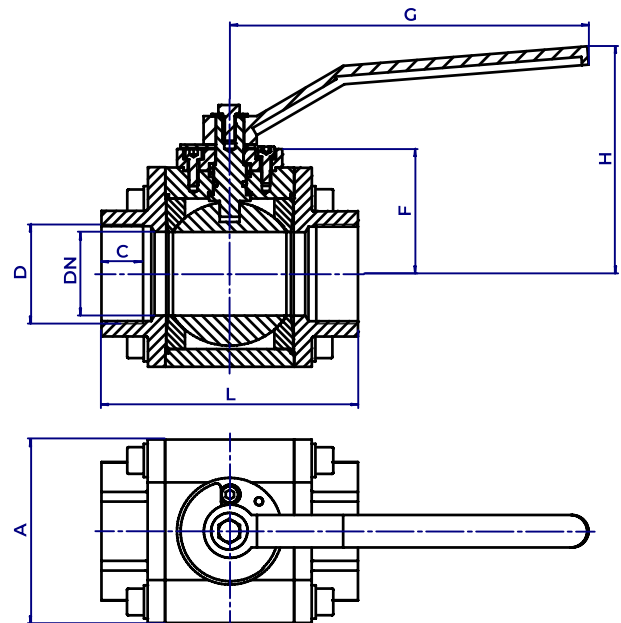

◆ Hydraulic tightness and sealing test according to EN 12266-1. 100% Valves tested.

BALL VALVE

2 Way. Threaded. Manual. Mild Steel PN40

CHARACTERISTICS

Design:

- ◆ Three-piece body. Full bore EN 1983.

OPTIONAL CHARACTERISTICS

Integrated Logistics Support (ILS):

- ◆ Technical Documentation (accessible by QR).
- ◆ Spare parts procurement (LCRS).
- ◆ Logistics engineering (obsolescence/costs).

WORKING CONDITIONS

Size	DN	8-50
Nominal pressure	PN	40
Maximum working pressure, kg/cm ²	Up to 100°C	40

MATERIALS

DRAWING	BODY	BALL	STEM	SEATS	BODY ENDS	BOLTING	LEVER
BR-206	Mild Steel A150/P355	Stainless Steel AISI316	Stainless Steel A316	PTFE	Mild Steel A150/P355	Stainless Steel A4	Stainless Steel AISI304

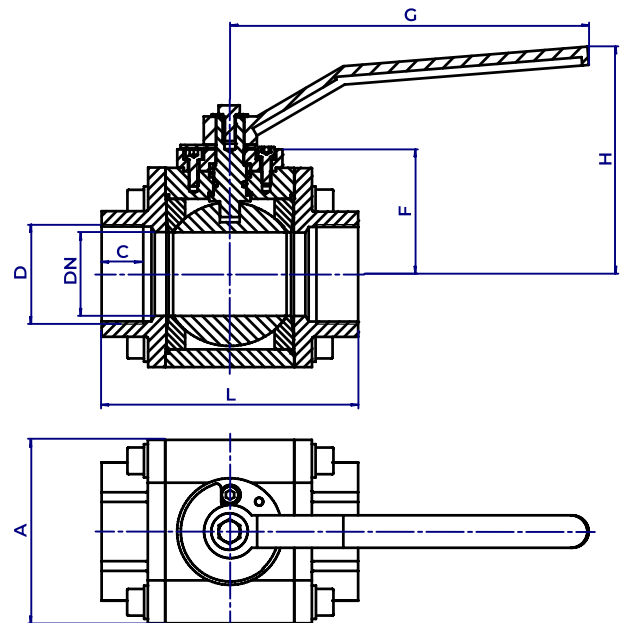

◆ Hydraulic tightness and sealing test according to EN 12266-1. 100% Valves tested.

DIMENSIONS

DN		ØD	A	L	C (min)	H	F	G	Weight	Code
Inches	mm	mm	mm	mm	mm	mm	mm	mm	[kg]	SAVAL
1/4	8	1/4	56	75	12	92	39	181	2	SDBF206N3AER40008
3/8	10	3/8	56	75	12	92	39	181	2	SDBF206N3AER40010
1/2	15	1/2	56	83	15	92	39	181	2	SDBF206N3AER40015
3/4	20	3/4	56	87	17	92	39	181	2	SDBF206N3AER40020
1	25	1	68	95	18	98	45	181	2,5	SDBF206N3AER40025
1 1/4	32	1 1/4	80	110	20	104	51	181	3,5	SDBF206N3AER40032
1 1/2	40	1 1/2	100	128	23	129	68	216	7	SDBF206N3AER40040
2	50	2	110	155	25	136	75	216	9,5	SDBF206N3AER40050

BALL VALVE

2 Way. Threaded. Manual. Stainless Steel PN40

CHARACTERISTICS

Design:

- ◆ Three-piece body. Full bore EN 1983.

OPTIONAL CHARACTERISTICS

Integrated Logistics Support (ILS):

- ◆ Technical Documentation (accessible by QR).
- ◆ Spare parts procurement (LCRS).
- ◆ Logistics engineering (obsolescence/costs).

WORKING CONDITIONS

Size	DN	8-50
Nominal pressure	PN	40
Maximum working pressure, kg/cm ²	Up to 100°C	38,1

MATERIALS

DRAWING	BODY	BALL	STEM	SEATS	BODY ENDS	BOLTING	LEVER
BR-606	Stainless Steel A316	Stainless Steel A316	Stainless Steel A316	PTFE	Stainless Steel A316	Stainless Steel A316	Stainless Steel AISI304

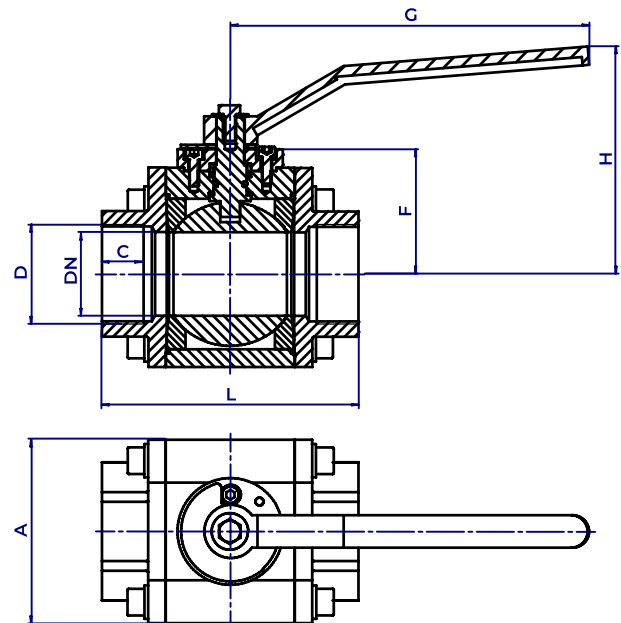

◆ Hydraulic tightness and sealing test according to EN 12266-1. 100% Valves tested.

DIMENSIONS

DN		ØD	A	L	C (min)	H	F	G	Weight	Code
Inches	mm	mm	mm	mm	mm	mm	mm	mm	[kg]	SAVAL
1/4	8	1/4	56	75	12	92	39	181	2	SDBF606N3AER40008
3/8	10	3/8	56	75	12	92	39	181	2	SDBF606N3AER40010
1/2	15	1/2	56	83	15	92	39	181	2	SDBF606N3AER40015
3/4	20	3/4	56	87	17	92	39	181	2	SDBF606N3AER40020
1	25	1	68	95	18	98	45	181	2,5	SDBF606N3AER40025
1 1/4	32	1 1/4	80	110	20	104	51	181	3,5	SDBF606N3AER40032
1 1/2	40	1 1/2	100	128	23	129	68	216	7	SDBF606N3AER40040
2	50	2	110	155	25	136	75	216	9,5	SDBF606N3AER40050