



GATE VALVES

GATE VALVE

Rising stem. Bronze PN 10/16

CHARACTERISTICS

Design:

- ◆ EN 12288.
- ◆ Face to face EN 558 series 14 (DIN 3202 F4).
- ◆ Flanges according to EN 1092.

OPTIONAL CHARACTERISTICS

- ◆ Possibility to be motorized

Integrated Logistics Support (ILS):

- ◆ Technical Documentation (accessible by QR).
- ◆ Spare parts procurement (LCRS).
- ◆ Logistics engineering (obsolescence/costs).

WORKING CONDITIONS

Size	DN	40-250	300-400
Nominal pressure	PN	10	16
Maximum working pressure, kg/cm ²	Up to 100°C	10	16
	Up to 225°C	6,6	10,7

MATERIALS

DRAWING	TYPE	BODY	SEAT	STEM	SCREWS	HANDWHEEL
CB-708	Rising stem	Bronze (Rg10) (DIN 1705)	CuAl10Fe5Ni5 (EN 1982/DIN 1714)	CuAl10Fe5Ni5 (EN 1982/DIN 1714)	Stainless S. A4	Nod. Cast Iron GGG40.3 or Iron GG25

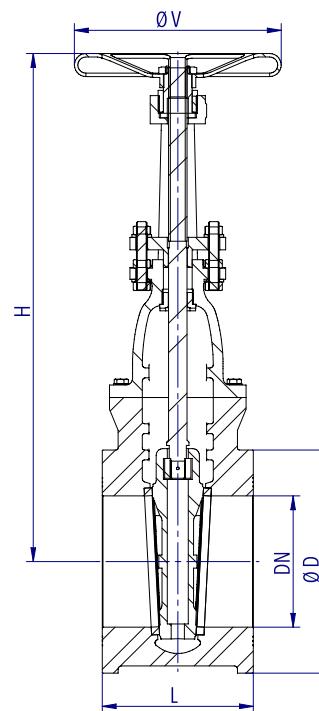

- ◆ Hydraulic tightness and sealing test according to EN 12266-1. 100% Valves tested.

DIMENSIONS

DN	Flanges	ØD	L	H	ØV	Weight	Code
mm	PN	mm	mm	mm	mm	[kg]	SAVAL
40	10/16	150	140	290	200	14	SDCB708TABR16040
50	10/16	165	150	305	200	16	SDCB708TABR16050
65	10/16	185	170	365	200	22	SDCB708TABR16065
80	10/16	200	180	420	200	26,5	SDCB708TABR16080
100	10/16	220	190	510	225	35	SDCB708TABR16100
125	10/16	250	200	545	225	46,5	SDCB708TABR16125
150	10/16	285	210	640	325	71,5	SDCB708TABR16150
200	10	340	230	770	325	120	SDCB708TABR10200
200	16	340	230	770	325	120	SDCB708TABR16200
250	10	395	250	905	375	139	SDCB708TABR10250
250	16	405	250	905	375	141	SDCB708TABR16250
300*	10	445	270	1060	375	257,5	SDCB708RDBR10300
350*	10	505	290	1250	450	363	SDCB708RDBR10350
400*	10	565	310	1370	450	441	SDCB708RDBR10400

*Supplied with gearbox.

GATE VALVE

Rising stem. Mild Steel PN 10/16

CHARACTERISTICS

Design:

- ◆ EN 1984.
- ◆ Face to face EN 558 series 14 (DIN 3202 F4).
- ◆ Flanges according to EN 1092.

OPTIONAL CHARACTERISTICS

- ◆ Possibility to be motorized

Integrated Logistics Support (ILS):

- ◆ Technical Documentation (accessible by QR).
- ◆ Spare parts procurement (LCRS).
- ◆ Logistics engineering (obsolescence/costs).

WORKING CONDITIONS

Size	DN	40-250	300-400
Nominal pressure	PN	10	16
Maximum working pressure, kg/cm ²	Up to 100°C	9,4	15
	Up to 225°C	8	12,8

MATERIALS

DRAWING	TYPE	BODY	SEAT	STEM	SCREWS	HANDWHEEL
CB-200	Rising Stem	Mild Steel (GS-C 25) (EN10213/DIN 17245)	Bronze (Rg5) (DIN 1705)	Brass (MS-58)	Mild Steel 8.8	Nod. Cast Iron GGG40.3 or Iron GG25
CB-202	Rising Stem	Mild Steel (GS-C 25) (EN10213/DIN 17245)	Stainless S. (AISI420)	Stainless S. (AISI420)	Mild Steel 8.8	Nod. Cast Iron GGG40.3 or Iron GG25

- ◆ Hydraulic tightness and sealing test according to EN 12266-1. 100% Valves tested.

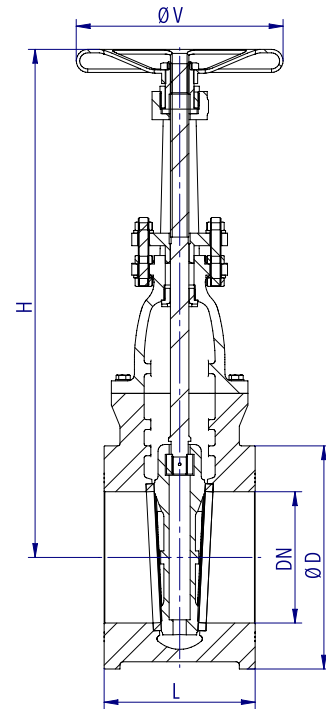

DIMENSIONS

DN	Flanges	ØD	L	H	ØV	Weight	Code
mm	PN	mm	mm	mm	mm	[kg]	SAVAL
40	10/16	150	140	290	200	12	SDCBxxxTABR16040
50	10/16	165	150	305	200	13,5	SDCBxxxTABR16050
65	10/16	185	170	365	200	19	SDCBxxxTABR16065
80	10/16	200	180	420	200	24	SDCBxxxTABR16080
100	10/16	220	190	510	225	32	SDCBxxxTABR16100
125	10/16	250	200	545	225	42,5	SDCBxxxTABR16125
150	10/16	285	210	640	325	65	SDCBxxxTABR16150
200	10	340	230	770	325	111	SDCBxxxTABR10200
200	16	340	230	770	325	111	SDCBxxxTABR16200
250	10	395	250	905	375	128,5	SDCBxxxTABR10250
250	16	405	250	905	375	130	SDCBxxxTABR16250
300*	10	445	270	1060	375	237	SDCBxxxRDBR10300
350*	10	505	290	1250	450	339	SDCBxxxRDBR10350
400*	10	565	310	1370	450	411	SDCBxxxRDBR10400

*Supplied with gearbox.
xxx = drawing number

GATE VALVE

Rising stem. Stainless Steel PN 10/16

CHARACTERISTICS

Design:

- ◆ EN 1984.
- ◆ Face to face EN 558 series 14 (DIN 3202 F4).
- ◆ Flanges according to EN 1092.

OPTIONAL CHARACTERISTICS

- ◆ Possibility to be motorized

Integrated Logistics Support (ILS):

- ◆ Technical Documentation (accessible by QR).
- ◆ Spare parts procurement (LCRS).
- ◆ Logistics engineering (obsolescence/costs).

WORKING CONDITIONS

Size	DN	40-250		300-400
Nominal pressure	PN	10	16	10
Maximum working pressure, kg/cm ²	Up to 100°C	9,5	15,2	9,5
	Up to 225°C	7,3	11,6	7,3

MATERIALS

DRAWING	TYPE	BODY	SEAT	STEM	SCREWS	HANDWHEEL
CB-606	Rising Stem	Stainless Steel A316 (EN10088/DIN 17440)	Stainless Steel A316 (EN10088/DIN 17440)	Stainless Steel A316 (EN10088/DIN 17440)	Stainless S. A4	Nod. Cast Iron GGG40.3 or Iron GG25

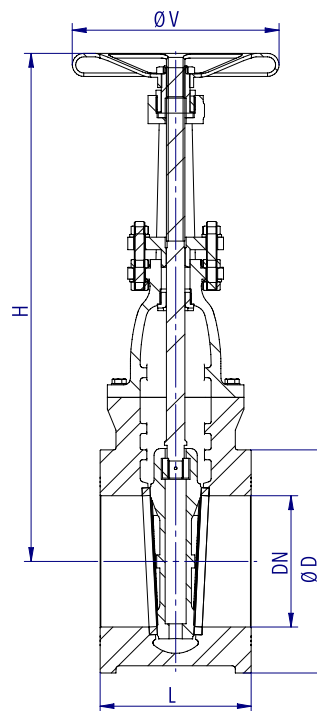

- ◆ Hydraulic tightness and sealing test according to EN 12266-1. 100% Valves tested.

DIMENSIONS

DN	Flanges	ØD	L	H	ØV	Weight	Code
mm	PN	mm	mm	mm	mm	[kg]	SAVAL
40	10/16	150	140	290	200	12	SDCB606TABR16040
50	10/16	165	150	305	200	13,5	SDCB606TABR16050
65	10/16	185	170	365	200	19	SDCB606TABR16065
80	10/16	200	180	420	200	24	SDCB606TABR16080
100	10/16	220	190	510	225	32	SDCB606TABR16100
125	10/16	250	200	545	225	42,5	SDCB606TABR16125
150	10/16	285	210	640	325	65	SDCB606TABR16150
200	10	340	230	770	325	111	SDCB606TABR10200
200	16	340	230	770	325	111	SDCB606TABR16200
250	10	395	250	905	375	128,5	SDCB606TABR10250
250	16	405	250	905	375	130	SDCB606TABR16250
300*	10	445	270	1060	375	237	SDCB606RDBR10300
350*	10	505	290	1250	450	339	SDCB606RDBR10350
400*	10	565	310	1370	450	411	SDCB606RDBR10400

*Supplied with gearbox.

GATE VALVE

Non rising stem. Bronze PN 10/16

CHARACTERISTICS

Design:

- ◆ EN 12288.
- ◆ Face to face EN 558 series 14 (DIN 3202 F4).
- ◆ Flanges according to EN 1092.

OPTIONAL CHARACTERISTICS

- ◆ Possibility to be motorized .
- ◆ Position indicator.

Integrated Logistics Support (ILS):

- ◆ Technical Documentation (accessible by QR).
- ◆ Spare parts procurement (LCRS).
- ◆ Logistics engineering (obsolescence/costs).

WORKING CONDITIONS

Size	DN	40-250	300-400
Nominal pressure	PN	10	16
Maximum working pressure, kg/cm ²	Up to 100°C	10	16
	Up to 225°C	6,6	6,6

MATERIALS

DRAWING	TYPE	BODY	SEAT	STEM	SCREWS	HANDWHEEL
C-708	Non rising stem	Bronze (Rg10) (DIN 1705)	CuAl10Fe5Ni5 (EN1982/DIN1714)	CuAl10Fe5Ni5 (EN1982/DIN1714)	Stainless S. A4	Aluminium
C-708 IN	Non rising stem indicator	Bronze (Rg10) (DIN 1705)	CuAl10Fe5Ni5 (EN1982/DIN1714)	CuAl10Fe5Ni5 (EN1982/DIN1714)	Stainless S. A4	Aluminium

DIMENSIONS

DN	Flanges	ØD	L	H	H-IN	ØV	Weight	Code
mm	PN	mm	mm	mm	mm	mm	[kg]	SAVAL
40	10/16	150	140	225	260	140	11	SDCO708YYBR16040
50	10/16	165	150	240	280	140	13,5	SDCO708YYBR16050
65	10/16	185	170	265	320	150	18	SDCO708YYBR16065
80	10/16	200	180	305	370	150	23,5	SDCO708YYBR16080
100	10/16	220	190	375	440	200	32,5	SDCO708YYBR16100
125	10/16	250	200	427	485	200	44,5	SDCO708YYBR16125
150	10/16	285	210	465	530	250	59,5	SDCO708YYBR16150
200	10	340	230	605	715	300	107	SDCO708YYBR10200
200	16	340	230	605	715	300	107	SDCO708YYBR16200
250	10	395	250	650	-	315	130	SDCO708YYBR10250
250	16	405	250	650	-	315	131	SDCO708YYBR16250
300*	10	445	270	820	-	315	230	SDCO708YYBR10300
350*	10	505	290	990	-	315	320,5	SDCO708YYBR10350
400*	10	565	310	1050	-	315	411	SDCO708YYBR10400

*Supplied with gearbox.

YY = TA: without indicator RD: Gearbox
IN: with indicator RI: Gearbox and indicator

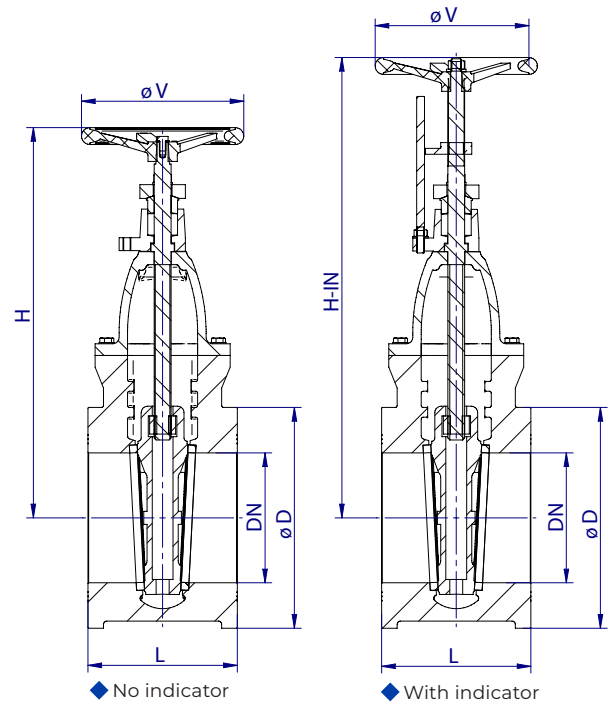

◆ Hydraulic tightness and sealing test according to EN 12266-1. 100% Valves tested.

GATE VALVE

Non rising stem. Mild Steel PN 10/16

CHARACTERISTICS

Design:

- ◆ EN 1984.
- ◆ Face to face EN 558 series 14 (DIN 3202 F4).
- ◆ Flanges according to EN 1092.

OPTIONAL CHARACTERISTICS

- ◆ Possibility to be motorized .
- ◆ Position indicator.

Integrated Logistics Support (ILS):

- ◆ Technical Documentation (accessible by QR).
- ◆ Spare parts procurement (LCRS).
- ◆ Logistics engineering (obsolescence/costs).

WORKING CONDITIONS

Size	DN	40-250	300-400
Nominal pressure	PN	10	16
Maximum working pressure, kg/cm ²	Up to 100°C	9,4	15
	Up to 225°C	8	12,8

MATERIALS

DRAWING	TYPE	BODY	SEAT	STEM	SCREWS	HANDWHEEL
C-200	Non rising stem	Mild Steel (GS-C 25) (EN10213/DIN 17245)	Bronze (Rg5) (DIN 1705)	Brass (MS-58)	Mild Steel 8.8	Aluminium
C-200 IN	Non rising stem indicator	Mild Steel (GS-C 25) (EN10213/DIN 17245)	Bronze (Rg5) (DIN 1705)	Brass (MS-58)	Mild Steel 8.8	Aluminium
C-202	Non rising stem	Mild Steel (GS-C 25) (EN10213/DIN 17245)	Stainless S. (AISI420)	Stainless S. (AISI420)	Mild Steel 8.8	Aluminium
C-202 IN	Non rising stem indicator	Mild Steel (GS-C 25) (EN10213/DIN 17245)	Stainless S. (AISI420)	Stainless S. (AISI420)	Mild Steel 8.8	Aluminium

DIMENSIONS

DN	Flanges	ØD	L	H	H-IN	ØV	Weight	Code
mm	PN	mm	mm	mm	mm	mm	[kg]	SAVAL
40	10/16	150	140	225	260	140	10	SDCOxxxYYBR16040
50	10/16	165	150	240	280	140	12	SDCOxxxYYBR16050
65	10/16	185	170	265	320	150	16,5	SDCOxxxYYBR16065
80	10/16	200	180	305	370	150	21	SDCOxxxYYBR16080
100	10/16	220	190	375	440	200	30	SDCOxxxYYBR16100
125	10/16	250	200	427	485	200	41	SDCOxxxYYBR16125
150	10/16	285	210	465	530	250	55,5	SDCOxxxYYBR16150
200	10	340	230	605	715	300	98	SDCOxxxYYBR10200
200	16	340	230	605	715	300	98	SDCOxxxYYBR16200
250	10	395	250	650	-	315	119	SDCOxxxYYBR10250
250	16	405	250	650	-	315	120	SDCOxxxYYBR16250
300*	10	445	270	820	-	315	211,5	SDCOxxxYYBR10300
350*	10	505	290	990	-	315	300	SDCOxxxYYBR10350
400*	10	565	310	1050	-	315	383	SDCOxxxYYBR10400

*Supplied with gearbox.
xxx = drawing number

YY = TA: without indicator RD: Gearbox
IN: with indicator RI: Gearbox and indicator

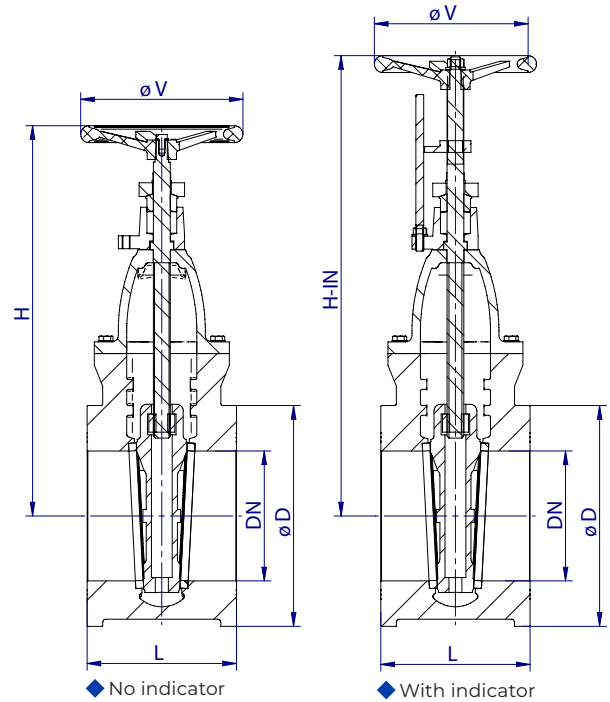

- ◆ Hydraulic tightness and sealing test according to EN 12266-1. 100% Valves tested.

GATE VALVE

Non rising stem. Stainless Steel PN 10/16

CHARACTERISTICS

Design:

- ◆ EN 1984.
- ◆ Face to face EN 558 series 14 (DIN 3202 F4).
- ◆ Flanges according to EN 1092.

OPTIONAL CHARACTERISTICS

- ◆ Possibility to be motorized .
- ◆ Position indicator.

Integrated Logistics Support (ILS):

- ◆ Technical Documentation (accessible by QR).
- ◆ Spare parts procurement (LCRS).
- ◆ Logistics engineering (obsolescence/costs).

WORKING CONDITIONS

Size	DN	40-250	300-400
Nominal pressure	PN	10	16
Maximum working pressure, kg/cm ²	Up to 100°C	9,5	15,2
	Up to 225°C	7,3	11,6

MATERIALS

DRAWING	TYPE	BODY	SEAT	STEM	SCREWS	HANDWHEEL
C-606	Non rising stem	Stainless S. A316 (EN10088/DIN 17440)	Stainless S. A316 (EN10088/DIN 17440)	Stainless S. A316 (EN10088/DIN 17440)	Stainless S. A4	Aluminium
C-606 IN	Non rising stem indicator	Stainless S. A316 (EN10088/DIN 17440)	Stainless S. A316 (EN10088/DIN 17440)	Stainless S. A316 (EN10088/DIN 17440)	Stainless S. A4	Aluminium

DIMENSIONS

DN	Flanges	ØD	L	H	H-IN	ØV	Weight	Code
mm	PN	mm	mm	mm	mm	mm	[kg]	SAVAL
40	10/16	150	140	225	260	140	10	SDCO606YYBR16040
50	10/16	165	150	240	280	140	12	SDCO606YYBR16050
65	10/16	185	170	265	320	150	16,5	SDCO606YYBR16065
80	10/16	200	180	305	370	150	21	SDCO606YYBR16080
100	10/16	220	190	375	440	200	30	SDCO606YYBR16100
125	10/16	250	200	427	485	200	41	SDCO606YYBR16125
150	10/16	285	210	465	530	250	55,5	SDCO606YYBR16150
200	10	340	230	605	715	300	98	SDCO606YYBR10200
200	16	340	230	605	715	300	98	SDCO606YYBR16200
250	10	395	250	650	-	315	119	SDCO606YYBR10250
250	16	405	250	650	-	315	120	SDCO606YYBR16250
300*	10	445	270	820	-	315	211,5	SDCO606YYBR10300
350*	10	505	290	990	-	315	300	SDCO606YYBR10350
400*	10	565	310	1050	-	315	383	SDCO606YYBR10400

*Supplied with gearbox.

YY = TA: without indicator RD: Gearbox
IN: with indicator RI: Gearbox and indicator

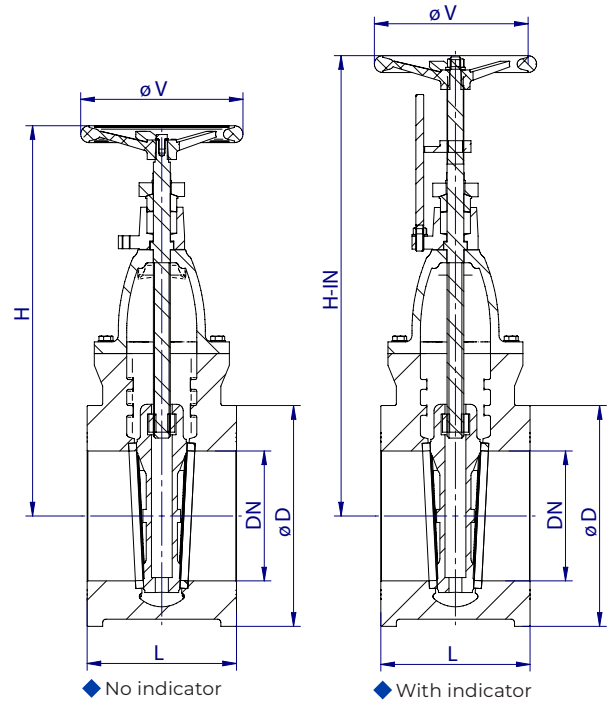

◆ Hydraulic tightness and sealing test according to EN 12266-1
100% Valves tested.