



## **GLOBE VALVES**

# GLOBE VALVE

Straight, SDNR Type. Bronze PN 10/16

## CHARACTERISTICS

### Design:

- ◆ EN 13789 (DIN 86262 part 5).
- ◆ Face to face EN 558 Series 1 (DIN 3202 F1).
- ◆ Flanges according to EN 1092 (DIN 2633).

## OPTIONAL CHARACTERISTICS

- ◆ Possibility to be motorized.
- ◆ Position indicator.

### Integrated Logistics Support (ILS):

- ◆ Technical Documentation (accessible by QR).
- ◆ Spare parts procurement (LCRS).
- ◆ Logistics engineering (obsolescence/costs).

## WORKING CONDITIONS

Size	DN	15-250	300-400
Nominal pressure	PN	10	16
Maximum working pressure, kg/cm <sup>2</sup>	Up to 100°C	10	16
	Up to 225°C	6,6	10,75

## MATERIALS

DRAWING	TYPE	BODY/BONNET	SEAT	STEM	SCREWS	HANDWHEEL
GA-708	SDNR	Bronze (Rg10) (DIN 1705)	CuAl10Fe5Ni5 (EN 1982/DIN 1714)	CuAl10Fe5Ni5 (EN 1982/DIN 1714)	Stainless S. A4	Aluminium

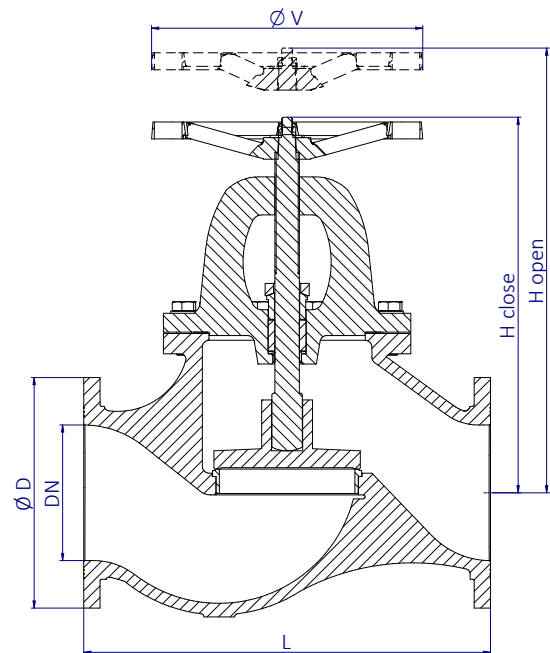

- ◆ Hydraulic tightness and sealing test according to EN 12266-1. 100% Valves tested.

## DIMENSIONS

DN	Flanges	ØD	L	Hc	Ho	ØV	Weight	Code
mm	PN	mm	mm	mm	mm	mm	[kg]	SAVAL
15	10/16	95	130	162	170	110	5	SDGA708TABR16015
20	10/16	105	150	166	174	110	6	SDGA708TABR16020
25	10/16	115	160	171	179	110	6,5	SDGA708TABR16025
32	10/16	140	180	218,5	235,5	150	11,5	SDGA708TABR16032
40	10/16	150	200	223	238,5	150	12	SDGA708TABR16040
50	10/16	165	230	231	246,5	150	14,5	SDGA708TABR16050
65	10/16	185	290	290	318,5	196	26,5	SDGA708TABR16065
80	10/16	200	310	290	318,5	196	32,5	SDGA708TABR16080
100	10/16	200	350	328	355,5	196	39	SDGA708TABR16100
125	10/16	250	400	409	450,5	298	75	SDGA708TABR16125
150	10/16	285	480	445	486,5	298	100,5	SDGA708TABR16150
200	10	340	600	569,5	613	388	185	SDGA708TABR10200
200	16	340	600	569,5	613	388	184,5	SDGA708TABR16200
250	10	395	730	640	709,5	500	252	SDGA708TABR10250
250	16	405	730	640	709,5	500	253,5	SDGA708TABR16250
300*	10	445	850	697	775	500	376,5	SDGA708RDBR10300
350*	10	505	980	778	860	600	519,5	SDGA708RDBR10350
400*	10	565	1100	915	1015,5	600	715	SDGA708RDBR10400

\*Supplied with gearbox.

## GLOBE VALVE

Straight, SDNR Type. Mild Steel PN 10/16

### CHARACTERISTICS

#### Design:

- ◆ EN 13709 (DIN 86262 part 5).
- ◆ Face to face EN 558 Series 1 (DIN 3202 F1).
- ◆ Flanges according to EN 1092 (DIN 2633).

### OPTIONAL CHARACTERISTICS

- ◆ Possibility to be motorized.
- ◆ Position indicator.

#### Integrated Logistics Support (ILS):

- ◆ Technical Documentation (accessible by QR).
- ◆ Spare parts procurement (LCRS).
- ◆ Logistics engineering (obsolescence/costs).

### WORKING CONDITIONS

Size	DN	15-250	300-400
Nominal pressure	PN	10	16
Maximum working pressure, kg/cm <sup>2</sup>	Up to 100°C	9,4	15
	Up to 225°C	8	12,85

### MATERIALS

DRAWING	TYPE	BODY/BONNET	SEAT	STEM	SCREWS	HANDWHEEL
GA-200	SDNR	Mild Steel (GS-C25) (EN10213/DIN17245)	Bronze (Rg5) (DIN 1705)	Brass (MS-58)	Mild Steel 8.8	Aluminium
GA-202	SDNR	Mild Steel (GS-C25) (EN10213/DIN17245)	Stainless S. (AISI420)	Stainless S. (AISI420)	Mild Steel 8.8	Aluminium
GA-206	SDNR	Mild Steel (GS-C25) (EN10213/DIN17245)	Stainless S. (AISI316)	Stainless S. (AISI316)	Mild Steel 8.8	Aluminium

### DIMENSIONS

DN	Flanges	ØD	L	Hc	Ho	ØV	Weight	Code
mm	PN	mm	mm	mm	mm	mm	[kg]	SAVAL
15	10/16	95	130	162	170	110	4,5	SDGxxxTABR16015
20	10/16	105	150	166	174	110	5,5	SDGxxxTABR16020
25	10/16	115	160	171	179	110	6	SDGxxxTABR16025
32	10/16	140	180	218,5	235,5	150	10,5	SDGxxxTABR16032
40	10/16	150	200	223	238,5	150	11	SDGxxxTABR16040
50	10/16	165	230	231	246,5	150	13	SDGxxxTABR16050
65	10/16	185	290	290	318,5	196	24,5	SDGxxxTABR16065
80	10/16	200	310	290	318,5	196	29,5	SDGxxxTABR16080
100	10/16	200	350	328	355,5	196	35,5	SDGxxxTABR16100
125	10/16	250	400	409	450,5	298	68	SDGxxxTABR16125
150	10/16	285	480	445	486,5	298	91	SDGxxxTABR16150
200	10	340	600	569,5	613	388	168	SDGxxxTABR10200
200	16	340	600	569,5	613	388	167,5	SDGxxxTABR16200
250	10	395	730	640	709,5	500	229,5	SDGxxxTABR10250
250	16	405	730	640	709,5	500	231	SDGxxxTABR16250
300*	10	445	850	697	775	500	343,5	SDGxxxRDBR10300
350*	10	505	980	778	860	600	473,5	SDGxxxRDBR10350
400*	10	565	1100	915	1015,5	600	651	SDGxxxRDBR10400

\*Supplied with gearbox.  
xxx = drawing number

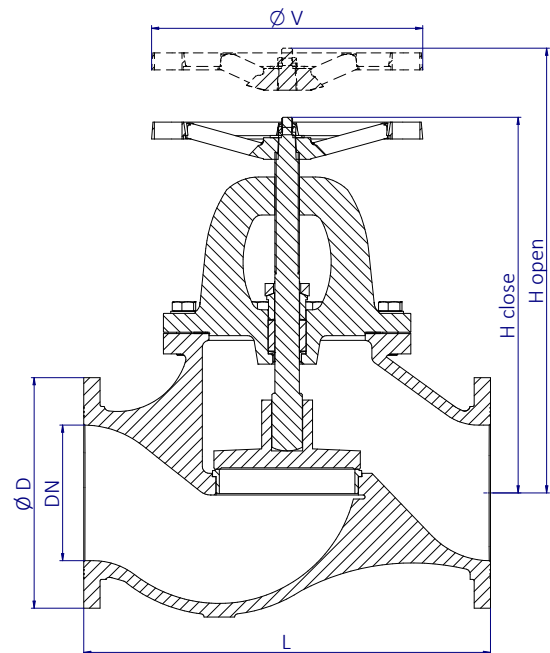

- ◆ Hydraulic tightness and seal test according to EN 12266-1.  
100% Valves tested.

# GLOBE VALVE

Straight, SDNR Type. Stainless Steel PN 10/16

## CHARACTERISTICS

### Design:

- ◆ EN 13709 (DIN 86262 part 5).
- ◆ Face to face EN 558 Series 1 (DIN 3202 F1).
- ◆ Flanges according to EN 1092 (DIN 2633).

## OPTIONAL CHARACTERISTICS

- ◆ Possibility to be motorized.
- ◆ Position indicator.

### Integrated Logistics Support (ILS):

- ◆ Technical Documentation (accessible by QR).
- ◆ Spare parts procurement (LCRS).
- ◆ Logistics engineering (obsolescence/costs).

## WORKING CONDITIONS

Size	DN	15-250	300-400
Nominal pressure	PN	10	16
Maximum working pressure, kg/cm <sup>2</sup>	Up to 100°C	9,5	15,2
	Up to 225°C	7,3	11,65

## MATERIALS

DRAWING	TYPE	BODY/BONNET	SEAT	STEM	SCREWS	HANDWHEEL
GA-606	SDNR	Stainless S. A316 (EN10088/DIN17440)	Stainless S. (AISI316)	Stainles S. (AISI316)	Stainless S. A4	Aluminium

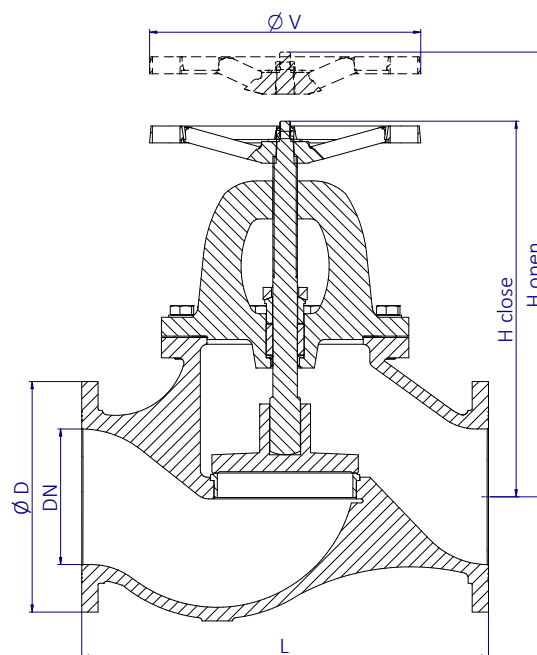

- ◆ Hydraulic tightness and seal test according to EN 12266-1. 100% Valves tested.

## DIMENSIONS

DN	Flanges	ØD	L	Hc	Ho	ØV	Weight	Code
mm	PN	mm	mm	mm	mm	mm	[kg]	SAVAL
15	10/16	95	130	162	170	110	4,5	SDGA606TABR16015
20	10/16	105	150	166	174	110	5,5	SDGA606TABR16020
25	10/16	115	160	171	179	110	6	SDGA606TABR16025
32	10/16	140	180	218,5	235,5	150	10,5	SDGA606TABR16032
40	10/16	150	200	223	238,5	150	11	SDGA606TABR16040
50	10/16	165	230	231	246,5	150	13,5	SDGA606TABR16050
65	10/16	185	290	290	318,5	196	24,5	SDGA606TABR16065
80	10/16	200	310	290	318,5	196	30	SDGA606TABR16080
100	10/16	200	350	328	355,5	196	36	SDGA606TABR16100
125	10/16	250	400	409	450,5	298	69	SDGA606TABR16125
150	10/16	285	480	445	486,5	298	92	SDGA606TABR16150
200	10	340	600	569,5	613	388	170,5	SDGA606TABR10200
200	16	340	600	569,5	613	388	170	SDGA606TABR16200
250	10	395	730	640	709,5	500	232,5	SDGA606TABR10250
250	16	405	730	640	709,5	500	234	SDGA606TABR16250
300*	10	445	850	697	775	500	347,5	SDGA606RDBR10300
350*	10	505	980	778	860	600	480	SDGA606RDBR10350
400*	10	565	1100	915	1015,5	600	660,5	SDGA606RDBR10400

\*Supplied with gearbox.

## GLOBE VALVE

Straight, SDNR Type. Nodular Cast Iron PN 10/16

### CHARACTERISTICS

#### Design:

- ◆ EN 13789 (DIN 3356 part 5).
- ◆ Face to face EN 558 Series 1 (DIN 3202 F1).
- ◆ Flanges according to EN 1092 (DIN 2633).

### OPTIONAL CHARACTERISTICS

- ◆ Possibility to be motorized.
- ◆ Position indicator.

#### Integrated Logistics Support (ILS):

- ◆ Technical Documentation (accessible by QR).
- ◆ Spare parts procurement (LCRS).
- ◆ Logistics engineering (obsolescence/costs).

### WORKING CONDITIONS

Size	DN	15-250	300-400
Nominal pressure	PN	10	16
Maximum working pressure, kg/cm <sup>2</sup>	Up to 100°C	10	16
	Up to 225°C	8,95	14,3

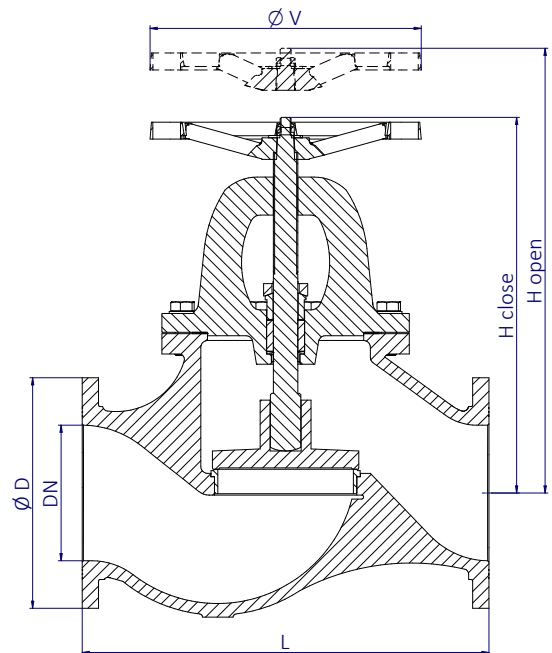

- ◆ Hydraulic tightness and sealing test according to EN 12266-1. 100% Valves tested.

### MATERIALS

DRAWING	TYPE	BODY/BONNET	SEAT	STEM	SCREWS	HANDWHEEL
GA-400	SDNR	Nodular Cast Iron (GJS400-18-LT)	Bronze (Rg5) (DIN 1705)	Brass (MS-58)	Mild Steel 8.8	Aluminium
GA-402	SDNR	Nodular Cast Iron (GJS400-18-LT)	Stainless S. (AISI420)	Stainless S. (AISI420)	Mild Steel 8.8	Aluminium

### DIMENSIONS

DN	Flanges	ØD	L	Hc	Ho	ØV	Weight	Code
mm	PN	mm	mm	mm	mm	mm	[kg]	SAVAL
15	10/16	95	130	162	170	110	4	SDGxxxTABR16015
20	10/16	105	150	166	174	110	5	SDGxxxTABR16020
25	10/16	115	160	171	179	110	5,5	SDGxxxTABR16025
32	10/16	140	180	218,5	235,5	150	10	SDGxxxTABR16032
40	10/16	150	200	223	238,5	150	10,5	SDGxxxTABR16040
50	10/16	165	230	231	246,5	150	12,5	SDGxxxTABR16050
65	10/16	185	290	290	318,5	196	23	SDGxxxTABR16065
80	10/16	200	310	290	318,5	196	27,5	SDGxxxTABR16080
100	10/16	200	350	328	355,5	196	33,5	SDGxxxTABR16100
125	10/16	250	400	409	450,5	298	64	SDGxxxTABR16125
150	10/16	285	480	445	486,5	298	85,5	SDGxxxTABR16150
200	10	340	600	569,5	613	388	156	SDGxxxTABR10200
200	16	340	600	569,5	613	388	157,5	SDGxxxTABR16200
250	10	395	730	640	709,5	500	215,5	SDGxxxTABR10250
250	16	405	730	640	709,5	500	271,5	SDGxxxTABR16250
300*	10	445	850	697	775	500	323	SDGxxxRDBR10300
350*	10	505	980	778	860	600	445	SDGxxxRDBR10350
400*	10	565	1100	915	1015,5	600	612	SDGxxxRDBR10400

\*Supplied with gearbox.  
xxx = drawing number

# GLOBE VALVE

Angle, SDNR Type. Bronze PN 10/16

## CHARACTERISTICS

### Design:

- ◆ EN 13789 (DIN 86262 part 5).
- ◆ Face to face EN 558 Series 8 (DIN 3202 F32).
- ◆ Flanges according to EN 1092 (DIN 2633).

## OPTIONAL CHARACTERISTICS

- ◆ Possibility to be motorized.
- ◆ Position indicator.

### Integrated Logistics Support (ILS):

- ◆ Technical Documentation (accessible by QR).
- ◆ Spare parts procurement (LCRS).
- ◆ Logistics engineering (obsolescence/costs).

## WORKING CONDITIONS

Size	DN	15-250	300-400
Nominal pressure	PN	10	16
Maximum working pressure, kg/cm <sup>2</sup>	Up to 100°C	10	16
	Up to 225°C	6,6	10,75

## MATERIALS

DRAWING	TYPE	BODY/BONNET	SEAT	STEM	SCREWS	HANDWHEEL
GA-718	SDNR	Bronze (Rg10) (DIN 1705)	CuAl10Fe5Ni5 (EN 1982/DIN 1714)	CuAl10Fe5Ni5 (EN 1982/DIN 1714)	Stainless S. A4	Aluminium

## DIMENSIONS

DN	Flanges	ØD	L	Hc	Ho	ØV	Weight	Code
mm	PN	mm	mm	mm	mm	mm	[kg]	SAVAL
15	10/16	95	75	151,5	159,5	110	5	SDGA718TABR16015
20	10/16	105	85	148	156	110	5,5	SDGA718TABR16020
25	10/16	115	90	145,5	153,5	110	6	SDGA718TABR16025
32	10/16	140	105	197	214,5	150	11	SDGA718TABR16032
40	10/16	150	115	195	210,5	150	12	SDGA718TABR16040
50	10/16	165	125	195	210,5	150	14	SDGA718TABR16050
65	10/16	185	145	241	267,5	196	25	SDGA718TABR16065
80	10/16	200	155	243	271,5	196	27	SDGA718TABR16080
100	10/16	200	175	266,5	293,5	196	35,5	SDGA718TABR16100
125	10/16	250	200	336	377,5	298	62,5	SDGA718TABR16125
150	10/16	285	225	355	404,5	298	78	SDGA718TABR16150
200	10	340	275	435	488	388	156	SDGA718TABR10200
200	16	340	275	435	488	388	155	SDGA718TABR16200
250	10	395	325	512	571	500	249,5	SDGA718TABR10250
250	16	405	325	512	571	500	251,5	SDGA718TABR16250
300*	10	445	375	553	635	500	289	SDGA718RDBR10300
350*	10	505	425	606	706	600	410	SDGA718RDBR10350
400*	10	565	475	728	828,5	600	597	SDGA718RDBR10400

\*Supplied with gearbox.

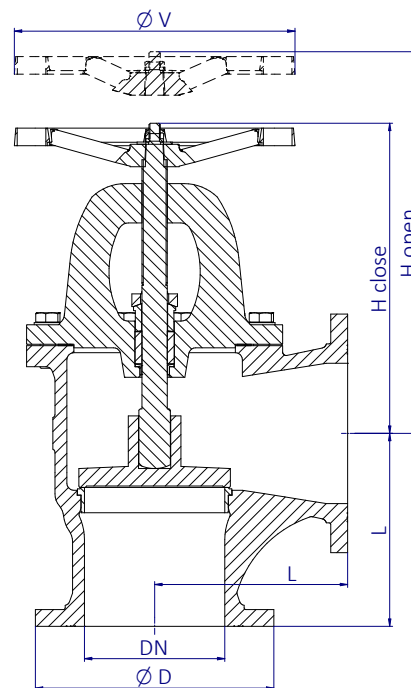

- ◆ Hydraulic tightness and sealing test according to EN 12266-1. 100% Valves tested.

# GLOBE VALVE

Angle, SDNR Type. Mild Steel PN 10/16

## CHARACTERISTICS

### Design:

- ◆ EN 13709 (DIN 86262 part 5).
- ◆ Face to face EN 558 Series 8 (DIN 3202 F32).
- ◆ Flanges according to EN 1092 (DIN 2633).

## OPTIONAL CHARACTERISTICS

- ◆ Possibility to be motorized.
- ◆ Position indicator.

### Integrated Logistics Support (ILS):

- ◆ Technical Documentation (accessible by QR).
- ◆ Spare parts procurement (LCRS).
- ◆ Logistics engineering (obsolescence/costs).

## WORKING CONDITIONS

Size	DN	15-250	300-400
Nominal pressure	PN	10	16
Maximum working pressure, kg/cm <sup>2</sup>	Up to 100°C	9,4	15
	Up to 225°C	8	12,85

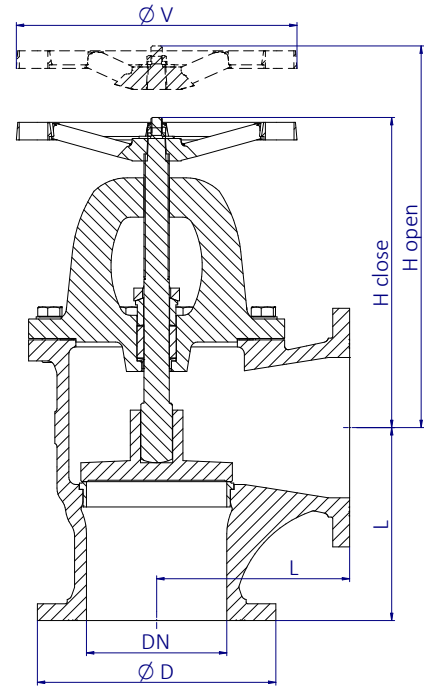

## MATERIALS

- ◆ Hydraulic tightness and seal test according to EN 12266-1. 100% Valves tested.

DRAWING	TYPE	BODY/BONNET	SEAT	STEM	SCREWS	HANDWHEEL
GA-210	SDNR	Mild Steel (GS-C25) (EN10213/DIN17245)	Bronze (Rg5) (DIN 1705)	Brass (MS-58)	Mild Steel 8.8	Aluminium
GA-212	SDNR	Mild Steel (GS-C25) (EN10213/DIN17245)	Stainless S. (AISI420)	Stainless S. (AISI420)	Mild Steel 8.8	Aluminium
GA-216	SDNR	Mild Steel (GS-C25) (EN10213/DIN17245)	Stainless S. (AISI316)	Stainless S. (AISI316)	Mild Steel 8.8	Aluminium

## DIMENSIONS

DN	Flanges	ØD	L	Hc	Ho	ØV	Weight	Code
mm	PN	mm	mm	mm	mm	mm	[kg]	SAVAL
15	10/16	95	75	151,5	159,5	110	4,5	SDGxxxTABR16015
20	10/16	105	85	148	156	110	5	SDGxxxTABR16020
25	10/16	115	90	145,5	153,5	110	5,5	SDGxxxTABR16025
32	10/16	140	105	197	214,5	150	10	SDGxxxTABR16032
40	10/16	150	115	195	210,5	150	11	SDGxxxTABR16040
50	10/16	165	125	195	210,5	150	13	SDGxxxTABR16050
65	10/16	185	145	241	267,5	196	23	SDGxxxTABR16065
80	10/16	200	155	243	271,5	196	26	SDGxxxTABR16080
100	10/16	200	175	266,5	293,5	196	32,5	SDGxxxTABR16100
125	10/16	250	200	336	377,5	298	57	SDGxxxTABR16125
150	10/16	285	225	355	404,5	298	71	SDGxxxTABR16150
200	10	340	275	435	488	388	142	SDGxxxTABR10200
200	16	340	275	435	488	388	141	SDGxxxTABR16200
250	10	395	325	512	571	500	227,5	SDGxxxTABR10250
250	16	405	325	512	571	500	229	SDGxxxTABR16250
300*	10	445	375	553	635	500	264	SDGxxxRDBR10300
350*	10	505	425	606	706	600	374,5	SDGxxxRDBR10350
400*	10	565	475	728	828,5	600	545	SDGxxxRDBR10400

\*Supplied with gearbox.  
xxx = drawing number

# GLOBE VALVE

Angle, SDNR Type. Stainless Steel PN 10/16

## CHARACTERISTICS

### Design:

- ◆ EN 13709 (DIN 86262 part 5).
- ◆ Face to face EN 558 Series 8 (DIN 3202 F32).
- ◆ Flanges according to EN 1092 (DIN 2633).

## OPTIONAL CHARACTERISTICS

- ◆ Possibility to be motorized.
- ◆ Position indicator.

### Integrated Logistics Support (ILS):

- ◆ Technical Documentation (accessible by QR).
- ◆ Spare parts procurement (LCRS).
- ◆ Logistics engineering (obsolescence/costs).

## WORKING CONDITIONS

Size	DN	15-250	300-400
Nominal pressure	PN	10	16
Maximum working pressure, kg/cm <sup>2</sup>	Up to 100°C	9,5	15,2
	Up to 225°C	7,3	11,65

## MATERIALS

DRAWING	TYPE	BODY/BONNET	SEAT	STEM	SCREWS	HANDWHEEL
GA-616	SDNR	Stainless S. A316 (EN10088/DIN17440)	Stainless S. (AISI316)	Stainless S. (AISI316)	Stainless S. A4	Aluminium

## DIMENSIONS

DN	Flanges	ØD	L	Hc	Ho	ØV	Weight	Code
mm	PN	mm	mm	mm	mm	mm	[kg]	SAVAL
15	10/16	95	75	151,5	159,5	110	4,5	SDGA616TABR16015
20	10/16	105	85	148	156	110	5	SDGA616TABR16020
25	10/16	115	90	145,5	153,5	110	5,5	SDGA616TABR16025
32	10/16	140	105	197	214,5	150	10	SDGA616TABR16032
40	10/16	150	115	195	210,5	150	11	SDGA616TABR16040
50	10/16	165	125	195	210,5	150	13	SDGA616TABR16050
65	10/16	185	145	241	267,5	196	23	SDGA616TABR16065
80	10/16	200	155	243	271,5	196	26,5	SDGA616TABR16080
100	10/16	200	175	266,5	293,5	196	33	SDGA616TABR16100
125	10/16	250	200	336	377,5	298	58	SDGA616TABR16125
150	10/16	285	225	355	404,5	298	72	SDGA616TABR16150
200	10	340	275	435	488	388	144	SDGA616TABR10200
200	16	340	275	435	488	388	143	SDGA616TABR16200
250	10	395	325	512	571	500	230	SDGA616TABR10250
250	16	405	325	512	571	500	232	SDGA616TABR16250
300*	10	445	375	553	635	500	268	SDGA616RDBR10300
350*	10	505	425	606	706	600	380	SDGA616RDBR10350
400*	10	565	475	728	828,5	600	553	SDGA616RDBR10400

\*Supplied with gearbox.

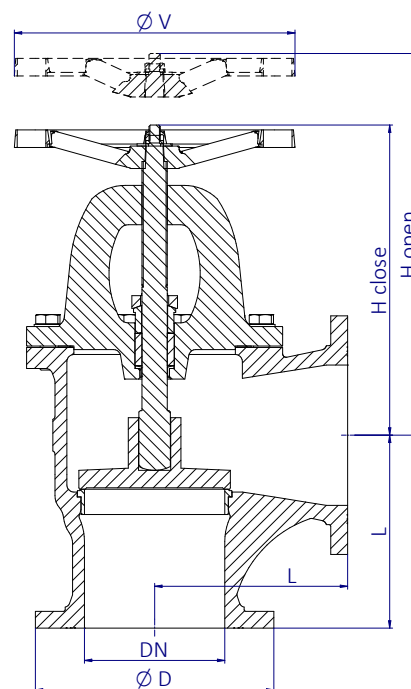

- ◆ Hydraulic tightness and seal test according to EN 12266-1. 100% Valves tested.

# GLOBE VALVE

Angle, SDNR Type. Nodular Cast Iron PN 10/16

## CHARACTERISTICS

### Design:

- ◆ EN 13789 (DIN 86262 part 5).
- ◆ Face to face EN 558 Series 8 (DIN 3202 F32).
- ◆ Flanges according to EN 1092 (DIN 2633).

## OPTIONAL CHARACTERISTICS

- ◆ Possibility to be motorized.
- ◆ Position indicator.

### Integrated Logistics Support (ILS):

- ◆ Technical Documentation (accessible by QR).
- ◆ Spare parts procurement (LCRS).
- ◆ Logistics engineering (obsolescence/costs).

## WORKING CONDITIONS

Size	DN	15-250	300-400
Nominal pressure	PN	10 16	10
Maximum working pressure, kg/cm <sup>2</sup>	Up to 100°C	10 16	10
	Up to 225°C	8,95 14,3	8,95

## MATERIALS

DRAWING	TYPE	BODY/BONNET	SEAT	STEM	SCREWS	HANDWHEEL
GA-410	SDNR	Nodular Cast Iron (GJS400-18-LT)(EN 1563)	Bronze (Rg5) (DIN 1705)	Brass (MS-58)	Mild Steel 8.8	Aluminium
GA-412	SDNR	Nodular Cast Iron (GJS400-18-LT)(EN 1563)	Stainless S. (AISI420)	Stainless S. (AISI420)	Mild Steel 8.8	Aluminium

- ◆ Hydraulic tightness and sealing test according to EN 12266-1. 100% Valves tested.

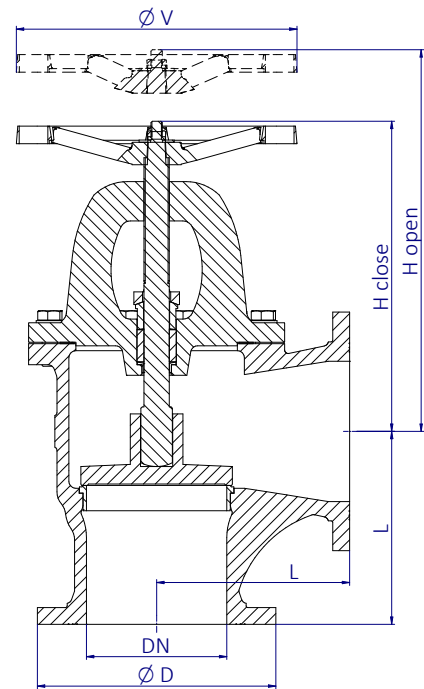

## DIMENSIONS

DN	Flanges	ØD	L	Hc	Ho	ØV	Weight	Code
mm	PN	mm	mm	mm	mm	mm	[kg]	SAVAL
15	10/16	95	75	151,5	159,5	110	4	SDGxxxTABR16015
20	10/16	105	85	148	156	110	4,5	SDGxxxTABR16020
25	10/16	115	90	145,5	153,5	110	5	SDGxxxTABR16025
32	10/16	140	105	197	214,5	150	9,5	SDGxxxTABR16032
40	10/16	150	115	195	210,5	150	10,5	SDGxxxTABR16040
50	10/16	165	125	195	210,5	150	12	SDGxxxTABR16050
65	10/16	185	145	241	267,5	196	21,5	SDGxxxTABR16065
80	10/16	200	155	243	271,5	196	24,5	SDGxxxTABR16080
100	10/16	200	175	266,5	293,5	196	30,5	SDGxxxTABR16100
125	10/16	250	200	336	377,5	298	54	SDGxxxTABR16125
150	10/16	285	225	355	404,5	298	67	SDGxxxTABR16150
200	10	340	275	435	488	388	133,5	SDGxxxTABR10200
200	16	340	275	435	488	388	133	SDGxxxTABR16200
250	10	395	325	512	571	500	214	SDGxxxTABR10250
250	16	405	325	512	571	500	215,5	SDGxxxTABR16250
300*	10	445	375	553	635	500	259	SDGxxxRDBR10300
350*	10	505	425	606	706	600	335	SDGxxxRDBR10350
400*	10	565	475	728	828,5	600	513	SDGxxxRDBR10400

\*Supplied with gearbox.  
xxx = drawing number

# GLOBE VALVE

Straight, Stop Type. Bronze PN 10/16

## CHARACTERISTICS

### Design:

- ◆ DIN 13789 (DIN3356 part 5).
- ◆ Face to face EN 558 Series 1 (DIN 3202 F1).
- ◆ Flanges according to EN 1092 (DIN 2633).

## OPTIONAL CHARACTERISTICS

- ◆ Possibility to be motorized.
- ◆ Position indicator.

### Integrated Logistics Support (ILS):

- ◆ Technical Documentation (accessible by QR).
- ◆ Spare parts procurement (LCRS).
- ◆ Logistics engineering (obsolescence/costs).

## WORKING CONDITIONS

Size	DN	15-250	300-400
Nominal pressure	PN	10	16
Maximum working pressure, kg/cm <sup>2</sup>	Up to 100°C	10	16
	Up to 225°C	6,6	10,7

## MATERIALS

DRAWING	TYPE	BODY/BONNET	SEAT	STEM	SCREWS	HANDWHEEL
G-708	Stop	Bronze (Rg10) (DIN 1705)	CuAl10Fe5Ni5 (EN 1982/DIN 1714)	CuAl10Fe5Ni5 (EN 1982/DIN 1714)	Stainless S. A4	Aluminium

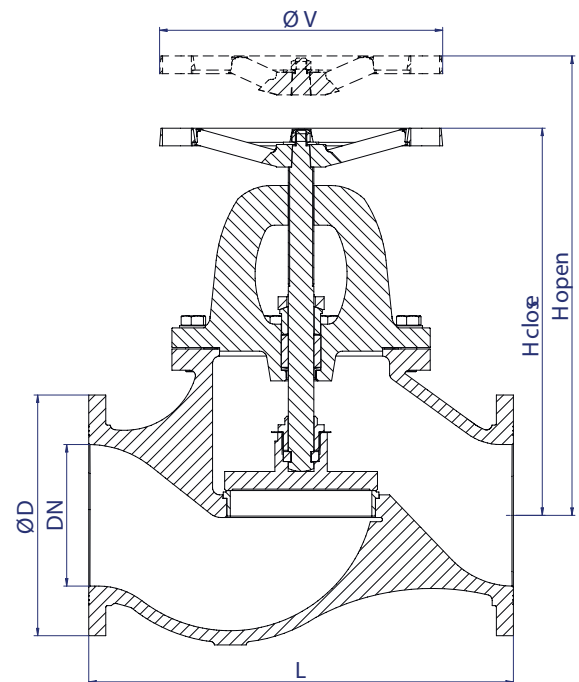

- ◆ Hydraulic tightness and sealing test according to EN 12266-1. 100% Valves tested.

## DIMENSIONS

DN	Flanges	ØD	L	Hc	Ho	ØV	Weight	Code
mm	PN	mm	mm	mm	mm	mm	[kg]	SAVAL
15	10/16	95	130	162	170	110	5	SDGL708TABR16015
20	10/16	105	150	166	174	110	6	SDGL708TABR16020
25	10/16	115	160	171	179	110	6,5	SDGL708TABR16025
32	10/16	140	180	218,5	235,5	150	11,5	SDGL708TABR16032
40	10/16	150	200	223	238,5	150	12	SDGL708TABR16040
50	10/16	165	230	231	246,5	150	14,5	SDGL708TABR16050
65	10/16	185	290	290	318,5	196	26,5	SDGL708TABR16065
80	10/16	200	310	290	318,5	196	32	SDGL708TABR16080
100	10/16	200	350	328	355,5	196	39,5	SDGL708TABR16100
125	10/16	250	400	409	450,5	298	74,5	SDGL708TABR16125
150	10/16	285	480	445	486,5	298	100	SDGL708TABR16150
200	10	340	600	559,5	610,5	388	184,5	SDGL708TABR10200
200	16	340	600	559,5	610,5	388	184	SDGL708TABR16200
250	10	395	730	633	691,5	500	263	SDGL708TABR10250
250	16	405	730	633	691,5	500	265	SDGL708TABR16250
300*	10	445	850	705,5	787	500	390	SDGL708RDBR10300
350*	10	505	980	787	875,5	600	516,5	SDGL708RDBR10350
400*	10	565	1100	898	1007	600	712	SDGL708RDBR10400

\*Supplied with gearbox.

## GLOBE VALVE

Straight, Stop Type. Mild Steel PN 10/16

### CHARACTERISTICS

#### Design:

- ◆ DIN 13709 (DIN3356 part 5).
- ◆ Face to face EN 558 Series 1 (DIN 3202 F1).
- ◆ Flanges according to EN 1092 (DIN 2633)

### OPTIONAL CHARACTERISTICS

- ◆ Possibility to be motorized.
- ◆ Position indicator.

#### Integrated Logistics Support (ILS):

- ◆ Technical Documentation (accessible by QR).
- ◆ Spare parts procurement (LCRS).
- ◆ Logistics engineering (obsolescence/costs).

### WORKING CONDITIONS

Size	DN	15-250	300-400
nominal pressure	PN	10	16
Maximum working pressure, kg/cm <sup>2</sup>	Up to 100°C	9,4	15
	Up to 225°C	8	12,85

### MATERIALS

DRAWING	TYPE	BODY/BONNET	SEAT	STEM	SCREWS	HANDWHEEL
G-200	Stop	Mild Steel (GS-C25) (EN10213/DIN17245)	Bronze (Rg5) (DIN 1705)	Brass (MS-58)	Mild Steel 8.8	Aluminium
G-202	Stop	Mild Steel (GS-C25) (EN10213/DIN17245)	Stainless S. (AISI420)	Stainless S. (AISI420)	Mild Steel 8.8	Aluminium
G-206	Stop	Mild Steel (GS-C25) (EN10213/DIN17245)	Stainless S. (AISI316)	Stainless S. (AISI316)	Mild Steel 8.8	Aluminium

- ◆ Hydraulic tightness and sealing test according to EN 12266-1. 100% Valves tested.

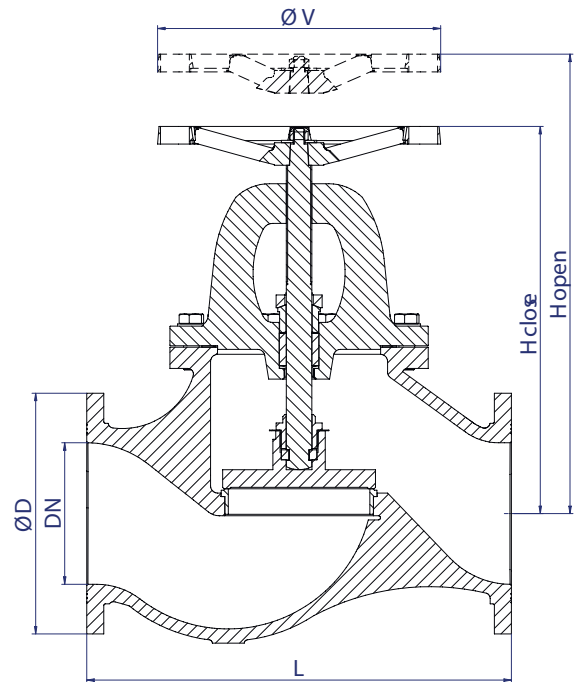

### DIMENSIONS

DN	Flanges	ØD	L	Hc	Ho	ØV	Weight	Code
mm	PN	mm	mm	mm	mm	mm	[kg]	SAVAL
15	10/16	95	130	162	170	110	4,5	SDGLxxxTABR16015
20	10/16	105	150	166	174	110	5,5	SDGLxxxTABR16020
25	10/16	115	160	171	179	110	6	SDGLxxxTABR16025
32	10/16	140	180	218,5	235,5	150	10,5	SDGLxxxTABR16032
40	10/16	150	200	223	238,5	150	11	SDGLxxxTABR16040
50	10/16	165	230	231	246,5	150	13	SDGLxxxTABR16050
65	10/16	185	290	290	318,5	196	24,5	SDGLxxxTABR16065
80	10/16	200	310	290	318,5	196	29	SDGLxxxTABR16080
100	10/16	200	350	328	355,5	196	36	SDGLxxxTABR16100
125	10/16	250	400	409	450,5	298	68	SDGLxxxTABR16125
150	10/16	285	480	445	486,5	298	91	SDGLxxxTABR16150
200	10	340	600	559,5	610,5	388	167,5	SDGLxxxTABR10200
200	16	340	600	559,5	610,5	388	167	SDGLxxxTABR16200
250	10	395	730	633	691,5	500	241	SDGLxxxTABR10250
250	16	405	730	633	691,5	500	242,5	SDGLxxxTABR16250
300*	10	445	850	705,5	787	500	356,5	SDGLxxxRDBR10300
350*	10	505	980	787	875,5	600	470,5	SDGLxxxRDBR10350
400*	10	565	1100	898	1007	600	648	SDGLxxxRDBR10400

\*Supplied with gearbox.  
xxx = drawing number

# GLOBE VALVE

Straight, Stop Type. Stainless Steel PN 10/16

## CHARACTERISTICS

### Design:

- ◆ DIN 13709 (DIN3356 part 5).
- ◆ Face to face EN 558 Series 1 (DIN 3202 F1).
- ◆ Flanges according to EN 1092 (DIN 2633).

## OPTIONAL CHARACTERISTICS

- ◆ Possibility to be motorized.
- ◆ Position indicator.

### Integrated Logistics Support (ILS):

- ◆ Technical Documentation (accessible by QR).
- ◆ Spare parts procurement (LCRS).
- ◆ Logistics engineering (obsolescence/costs).

## WORKING CONDITIONS

Size	DN	15-250	300-400	
Nominal pressure	PN	10	16	10
Maximum working pressure, kg/cm <sup>2</sup>	Up to 100°C	9,5	15,2	9,5
	Up to 225°C	7,3	11,65	7,3

## MATERIALS

DRAWING	TYPE	BODY/BONNET	SEAT	STEM	SCREWS	HANDWHEEL
G-606	Stop	Stainless S. A316 (EN10088/DIN17440)	Stainless S. (AISI316)	Stainless S. (AISI316)	Stainless S. A4	Aluminium

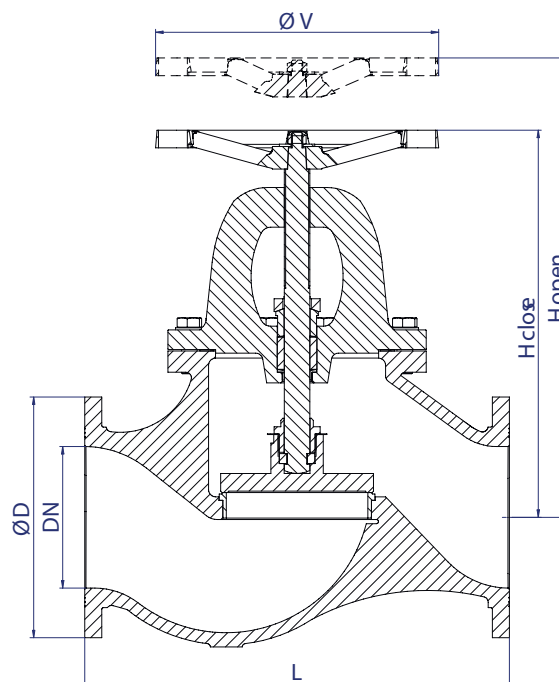

- ◆ Hydraulic tightness and sealing test according to EN 12266-1. 100% Valves tested.

## DIMENSIONS

DN	Flanges	ØD	L	Hc	Ho	ØV	Weight	Code
mm	PN	mm	mm	mm	mm	mm	[kg]	SAVAL
15	10/16	95	130	162	170	110	4,5	SDGL606TABR16015
20	10/16	105	150	166	174	110	5,5	SDGL606TABR16020
25	10/16	115	160	171	179	110	6	SDGL606TABR16025
32	10/16	140	180	218,5	235,5	150	10,5	SDGL606TABR16032
40	10/16	150	200	223	238,5	150	11	SDGL606TABR16040
50	10/16	165	230	231	246,5	150	13	SDGL606TABR16050
65	10/16	185	290	290	318,5	196	24,5	SDGL606TABR16065
80	10/16	200	310	290	318,5	196	30	SDGL606TABR16080
100	10/16	200	350	328	355,5	196	36	SDGL606TABR16100
125	10/16	250	400	409	450,5	298	69	SDGL606TABR16125
150	10/16	285	480	445	486,5	298	91	SDGL606TABR16150
200	10	340	600	559,5	610,5	388	170	SDGL606TABR10200
200	16	340	600	559,5	610,5	388	169	SDGL606TABR16200
250	10	395	730	633	691,5	500	244	SDGL606TABR10250
250	16	405	730	633	691,5	500	245,5	SDGL606TABR16250
300*	10	445	850	705,5	787	500	361	SDGL606RDBR10300
350*	10	505	980	787	875,5	600	477	SDGL606RDBR10350
400*	10	565	1100	898	1007	600	657	SDGL606RDBR10400

\*Supplied with gearbox.

## GLOBE VALVE

Straight, Stop Type. Nodular Cast Iron PN 10/16

### CHARACTERISTICS

#### Design:

- ◆ DIN 13789 (DIN3356 part 5).
- ◆ Face to face EN 558 Series 1 (DIN 3202 F1).
- ◆ Flanges according to EN 1092 (DIN 2633).

### OPTIONAL CHARACTERISTICS

- ◆ Possibility to be motorized.
- ◆ Position indicator.

#### Integrated Logistics Support (ILS):

- ◆ Technical Documentation (accessible by QR).
- ◆ Spare parts procurement (LCRS).
- ◆ Logistics engineering (obsolescence/costs).

### WORKING CONDITIONS

Size	DN	15-250	300-400
Nominal pressure	PN	10	16
Maximum working pressure, kg/cm <sup>2</sup>	Up to 100°C	10	16
	Up to 225°C	8,95	14,3

### MATERIALS

DRAWING	TYPE	BODY/BONNET	SEAT	STEM	SCREWS	HANDWHEEL
G-400	Stop	Nodular Cast Iron (GJS400-18-LT)	Bronze (Rg5) (DIN 1705)	Brass (MS-58)	Mild Steel 8.8	Aluminium
G-402	Stop	Nodular Cast Iron (GJS400-18-LT)	Stainless S. (AISI420)	Stainless S. (AISI420)	Mild Steel 8.8	Aluminium

- ◆ Hydraulic tightness and sealing test according to EN 12266-1. 100% Valves tested.

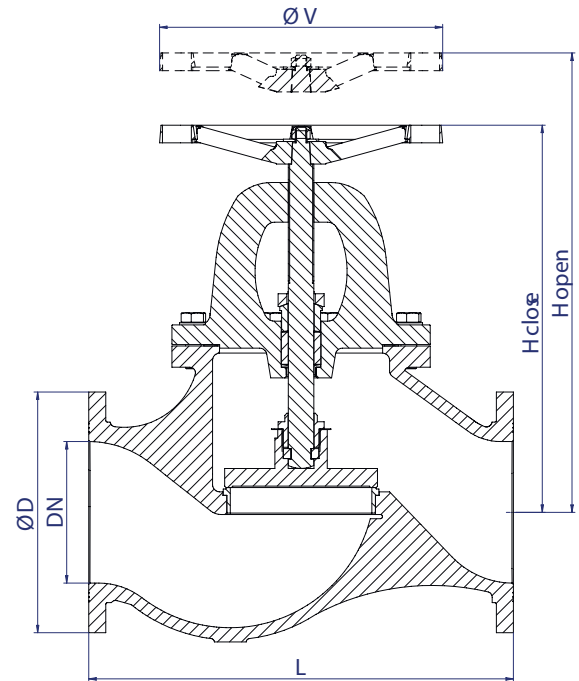

### DIMENSIONS

DN	Flanges	ØD	L	Hc	Ho	ØV	Weight	Code
mm	PN	mm	mm	mm	mm	mm	[kg]	SAVAL
15	10/16	95	130	162	170	110	4	SDGLxxxTABR16015
20	10/16	105	150	166	174	110	5	SDGLxxxTABR16020
25	10/16	115	160	171	179	110	5,5	SDGLxxxTABR16025
32	10/16	140	180	218,5	235,5	150	10	SDGLxxxTABR16032
40	10/16	150	200	223	238,5	150	10	SDGLxxxTABR16040
50	10/16	165	230	231	246,5	150	12,5	SDGLxxxTABR16050
65	10/16	185	290	290	318,5	196	23	SDGLxxxTABR16065
80	10/16	200	310	290	318,5	196	27,5	SDGLxxxTABR16080
100	10/16	200	350	328	355,5	196	33,5	SDGLxxxTABR16100
125	10/16	250	400	409	450,5	298	64	SDGLxxxTABR16125
150	10/16	285	480	445	486,5	298	85	SDGLxxxTABR16150
200	10	340	600	559,5	610,5	388	157	SDGLxxxTABR10200
200	16	340	600	559,5	610,5	388	157	SDGLxxxTABR16200
250	10	395	730	633	691,5	500	227	SDGLxxxTABR10250
250	16	405	730	633	691,5	500	229	SDGLxxxTABR16250
300*	10	445	850	705,5	787	500	336	SDGLxxxRDBR10300
350*	10	505	980	787	875,5	600	442,5	SDGLxxxRDBR10350
400*	10	565	1100	898	1007	600	609	SDGLxxxRDBR10400

\*Supplied with gearbox.  
xxx = drawing number

# GLOBE VALVE

Angle, Stop Type. Bronze PN 10/16

## CHARACTERISTICS

### Design:

- ◆ EN 13789 (DIN 3356 part 5).
- ◆ Face to face EN 558 Series 8 (DIN 3202 F32).
- ◆ Flanges according to EN 1092 (DIN 2633).

## OPTIONAL CHARACTERISTICS

- ◆ Possibility to be motorized.
- ◆ Position indicator.

### Integrated Logistics Support (ILS):

- ◆ Technical Documentation (accessible by QR).
- ◆ Spare parts procurement (LCRS).
- ◆ Logistics engineering (obsolescence/costs).

## WORKING CONDITIONS

Size	DN	15-250	300-400
Nominal pressure	PN	10	16
Maximum working pressure, kg/cm <sup>2</sup>	Up to 100°C	10	16
	Up to 225°C	6,6	10,75

## MATERIALS

DRAWING	TYPE	BODY/BONNET	SEAT	STEM	SCREWS	HANDWHEEL
G-718	Stop	Bronze (Rg10) (DIN 1705)	CuAl10Fe5Ni5 (EN 1982/DIN 1714)	CuAl10Fe5Ni5 (EN 1982/DIN 1714)	Stainless S. A4	Aluminium

## DIMENSIONS

DN	Flanges	ØD	L	Hc	Ho	ØV	Weight	Code
mm	PN	mm	mm	mm	mm	mm	[kg]	SAVAL
15	10/16	95	75	151,5	159,5	110	5	SDGL718TABR16015
20	10/16	105	85	148	156	110	5,5	SDGL718TABR16020
25	10/16	115	90	145,5	153,5	110	6	SDGL718TABR16025
32	10/16	140	105	197	214,5	150	11	SDGL718TABR16032
40	10/16	150	115	195	210,5	150	12	SDGL718TABR16040
50	10/16	165	125	195	210,5	150	14	SDGL718TABR16050
65	10/16	185	145	241	267,5	196	25,5	SDGL718TABR16065
80	10/16	200	155	243	271,5	196	29	SDGL718TABR16080
100	10/16	200	175	266,5	293,5	196	35,5	SDGL718TABR16100
125	10/16	250	200	336	377,5	298	62,5	SDGL718TABR16125
150	10/16	285	225	355	404,5	298	78	SDGL718TABR16150
200	10	340	275	435	488	388	155	SDGL718TABR10200
200	16	340	275	435	488	388	154,5	SDGL718TABR16200
250	10	395	325	512	571	500	261	SDGL718TABR10250
250	16	405	325	512	571	500	263	SDGL718TABR16250
300*	10	445	375	553	635	500	302,5	SDGL718RDBR10300
350*	10	505	425	606	706	600	415,5	SDGL718RDBR10350
400*	10	565	475	711	820	600	600	SDGL718RDBR10400

\*Supplied with gearbox.

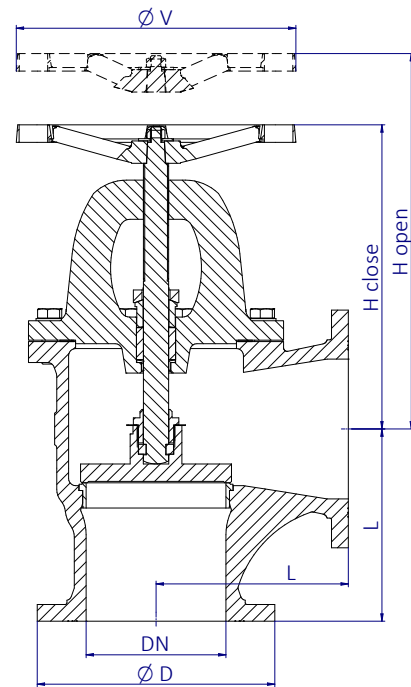

- ◆ Hydraulic tightness and sealing test according to EN 12266-1. 100% Valves tested.

# GLOBE VALVE

Angle, Stop Type. Mild Steel PN 10/16

## CHARACTERISTICS

### Design:

- ◆ EN 13709 (DIN 3356 part 5).
- ◆ Face to face EN 558 Series 8 (DIN 3202 F32).
- ◆ Flanges according to EN 1092 (DIN 2633).

## OPTIONAL CHARACTERISTICS

- ◆ Possibility to be motorized.
- ◆ Position indicator.

### Integrated Logistics Support (ILS):

- ◆ Technical Documentation (accessible by QR).
- ◆ Spare parts procurement (LCRS).
- ◆ Logistics engineering (obsolescence/costs).

## WORKING CONDITIONS

Size	DN	15-250	300-400
Nominal pressure	PN	10	16
Maximum working pressure, kg/cm <sup>2</sup>	Up to 100°C	9,4	15
	Up to 225°C	8	12,85

## MATERIALS

DRAWING	TYPE	BODY/BONNET	SEAT	STEM	SCREWS	HANDWHEEL
G-210	Stop	Mild Steel (GS-C25) (EN10213/DIN17245)	Bronze (Rg5) (DIN 1705)	Brass (MS-58)	Mild Steel 8.8	Aluminium
G-212	Stop	Mild Steel (GS-C25) (EN10213/DIN17245)	Stainless S. (AISI420)	Stainless S. (AISI420)	Mild Steel 8.8	Aluminium
G-216	Stop	Mild Steel (GS-C25) (EN10213/DIN17245)	Stainless S. (AISI316)	Stainless S. (AISI316)	Mild Steel 8.8	Aluminium

## DIMENSIONS

DN	Flanges	ØD	L	Hc	Ho	ØV	Weight	Code
mm	PN	mm	mm	mm	mm	mm	[kg]	SAVAL
15	10/16	95	75	151,5	159,5	110	4,5	SDGLxxxTABR16015
20	10/16	105	85	148	156	110	5	SDGLxxxTABR16020
25	10/16	115	90	145,5	153,5	110	5,5	SDGLxxxTABR16025
32	10/16	140	105	197	214,5	150	10	SDGLxxxTABR16032
40	10/16	150	115	195	210,5	150	11	SDGLxxxTABR16040
50	10/16	165	125	195	210,5	150	13	SDGLxxxTABR16050
65	10/16	185	145	241	267,5	196	23	SDGLxxxTABR16065
80	10/16	200	155	243	271,5	196	26,5	SDGLxxxTABR16080
100	10/16	200	175	266,5	293,5	196	32,5	SDGLxxxTABR16100
125	10/16	250	200	336	377,5	298	57	SDGLxxxTABR16125
150	10/16	285	225	355	404,5	298	71	SDGLxxxTABR16150
200	10	340	275	435	488	388	141	SDGLxxxTABR10200
200	16	340	275	435	488	388	141	SDGLxxxTABR16200
250	10	395	325	512	571	500	239	SDGLxxxTABR10250
250	16	405	325	512	571	500	240,5	SDGLxxxTABR16250
300*	10	445	375	553	635	500	278	SDGLxxxRDBR10300
350*	10	505	425	606	706	600	380	SDGLxxxRDBR10350
400*	10	565	475	711	820	600	547,5	SDGLxxxRDBR10400

\*Supplied with gearbox.  
xxx = drawing number

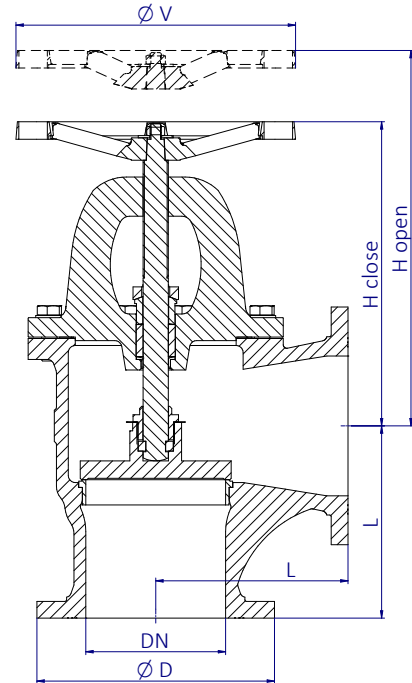

- ◆ Hydraulic tightness and seal test according to EN 12266-1. 100% Valves tested.

# GLOBE VALVE

Angle, Stop Type. Stainless Steel PN 10/16

## CHARACTERISTICS

### Design:

- ◆ EN 13709 (DIN 3356 part 5).
- ◆ Face to face EN 558 Series 8 (DIN 3202 F32).
- ◆ Flanges according to EN 1092 (DIN 2633).

## OPTIONAL CHARACTERISTICS

- ◆ Possibility to be motorized.
- ◆ Position indicator.

### Integrated Logistics Support (ILS):

- ◆ Technical Documentation (accessible by QR).
- ◆ Spare parts procurement (LCRS).
- ◆ Logistics engineering (obsolescence/costs).

## WORKING CONDITIONS

Size	DN	15-250	300-400	
Nominal pressure	PN	10	16	10
Maximum working pressure, kg/cm <sup>2</sup>	Up to 100°C	9,5	15,2	9,5
	Up to 225°C	7,3	11,65	7,3

## MATERIALS

DRAWING	TYPE	BODY/BONNET	SEAT	STEM	SCREWS	HANDWHEEL
G-616	Stop	Stainless S. A316 (EN10088/DIN17440)	Stainless S. (AISI316)	Stainless S. (AISI316)	Stainless S. A4	Aluminium

## DIMENSIONS

DN	Flanges	ØD	L	Hc	Ho	ØV	Weight	Code
mm	PN	mm	mm	mm	mm	mm	[kg]	SAVAL
15	10/16	95	75	151,5	159,5	110	4,5	SDGL616TABR16015
20	10/16	105	85	148	156	110	5	SDGL616TABR16020
25	10/16	115	90	145,5	153,5	110	5,5	SDGL616TABR16025
32	10/16	140	105	197	214,5	150	10	SDGL616TABR16032
40	10/16	150	115	195	210,5	150	11	SDGL616TABR16040
50	10/16	165	125	195	210,5	150	13	SDGL616TABR16050
65	10/16	185	145	241	267,5	196	23,5	SDGL616TABR16065
80	10/16	200	155	243	271,5	196	27	SDGL616TABR16080
100	10/16	200	175	266,5	293,5	196	33	SDGL616TABR16100
125	10/16	250	200	336	377,5	298	57,5	SDGL616TABR16125
150	10/16	285	225	355	404,5	298	72	SDGL616TABR16150
200	10	340	275	435	488	388	143	SDGL616TABR10200
200	16	340	275	435	488	388	142,5	SDGL616TABR16200
250	10	395	325	512	571	500	242	SDGL616TABR10250
250	16	405	325	512	571	500	243,5	SDGL616TABR16250
300*	10	445	375	553	635	500	282	SDGL616RDBR10300
350*	10	505	425	606	706	600	385,5	SDGL616RDBR10350
400*	10	565	475	711	820	600	555	SDGL616RDBR10400

\*Supplied with gearbox.

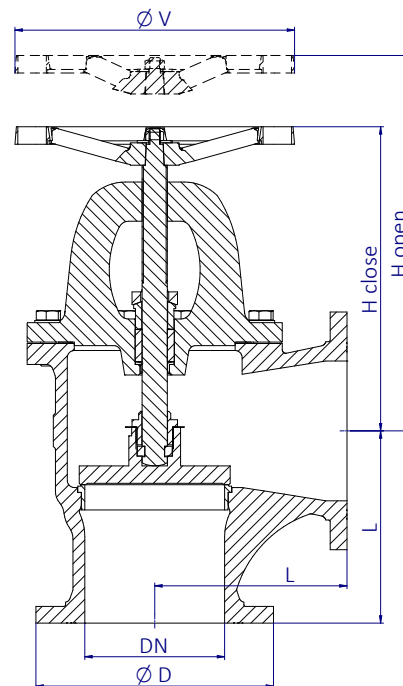

- ◆ Hydraulic tightness and sealing test according to EN 12266-1. 100% Valves tested.

# GLOBE VALVE

Angle, Stop Type. Nodular Cast Iron PN 10/16

## CHARACTERISTICS

### Design:

- ◆ EN 13789 (DIN 3356 part 5).
- ◆ Face to face EN 558 Series 8 (DIN 3202 F32).
- ◆ Flanges according to EN 1092 (DIN 2633).

## OPTIONAL CHARACTERISTICS

- ◆ Possibility to be motorized.
- ◆ Position indicator.

### Integrated Logistics Support (ILS):

- ◆ Technical Documentation (accessible by QR).
- ◆ Spare parts procurement (LCRS).
- ◆ Logistics engineering (obsolescence/costs).

## WORKING CONDITIONS

Size	DN	15-250	300-400
Nominal pressure	PN	10	16
Maximum working pressure, kg/cm <sup>2</sup>	Up to 100°C	10	16
	Up to 225°C	8,95	14,3

## MATERIALS

DRAWING	TYPE	BODY/BONNET	SEAT	STEM	SCREWS	HANDWHEEL
G-410	Stop	Nodular Cast Iron (GJS400-18-LT)(EN 1563)	Bronze (Rg5) (DIN 1705)	Brass (MS-58)	Mild Steel 8.8	Aluminium
G-412	Stop	Nodular Cast Iron (GJS400-18-LT)(EN 1563)	Stainless S. (AISI420)	Stainless S. (AISI420)	Mild Steel 8.8	Aluminium

- ◆ Hydraulic tightness and sealing test according to EN 12266-1. 100% Valves tested.

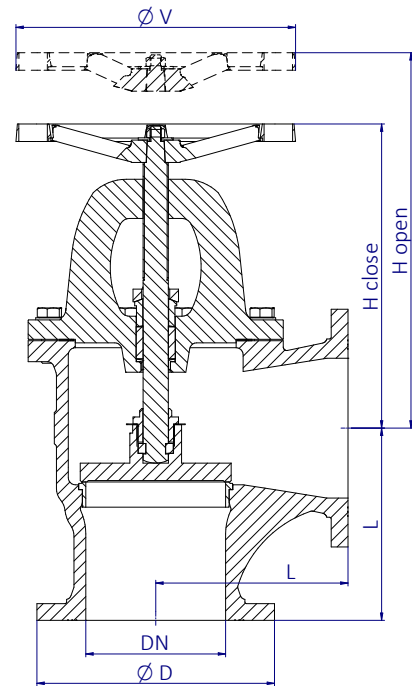

## DIMENSIONS

DN	Flanges	ØD	L	Hc	Ho	ØV	Weight	Code
mm	PN	mm	mm	mm	mm	mm	[kg]	SAVAL
15	10/16	95	75	151,5	159,5	110	4	SDGLxxxTABR16015
20	10/16	105	85	148	156	110	4,5	SDGLxxxTABR16020
25	10/16	115	90	145,5	153,5	110	5	SDGLxxxTABR16025
32	10/16	140	105	197	214,5	150	9,5	SDGLxxxTABR16032
40	10/16	150	115	195	210,5	150	10,5	SDGLxxxTABR16040
50	10/16	165	125	195	210,5	150	12	SDGLxxxTABR16050
65	10/16	185	145	241	267,5	196	22	SDGLxxxTABR16065
80	10/16	200	155	243	271,5	196	25	SDGLxxxTABR16080
100	10/16	200	175	266,5	293,5	196	30,5	SDGLxxxTABR16100
125	10/16	250	200	336	377,5	298	53,5	SDGLxxxTABR16125
150	10/16	285	225	355	404,5	298	66,5	SDGLxxxTABR16150
200	10	340	275	435	488	388	133	SDGLxxxTABR10200
200	16	340	275	435	488	388	132,5	SDGLxxxTABR16200
250	10	395	325	512	571	500	225,5	SDGLxxxTABR10250
250	16	405	325	512	571	500	227	SDGLxxxTABR16250
300*	10	445	375	553	635	500	263	SDGLxxxRDBR10300
350*	10	505	425	606	706	600	358,5	SDGLxxxRDBR10350
400*	10	565	475	711	820	600	515,5	SDGLxxxRDBR10400

\*Supplied with gearbox.  
xxx = drawing number